

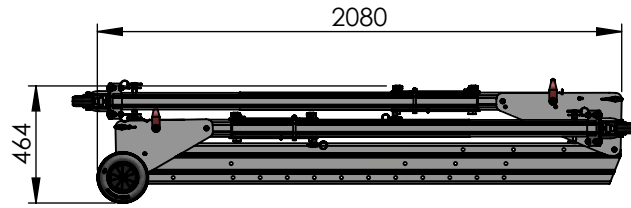

TECHNICAL DATASHEETS

# PORTAGANTRY RAPIDE<sup>®</sup>

1000kg



Folded

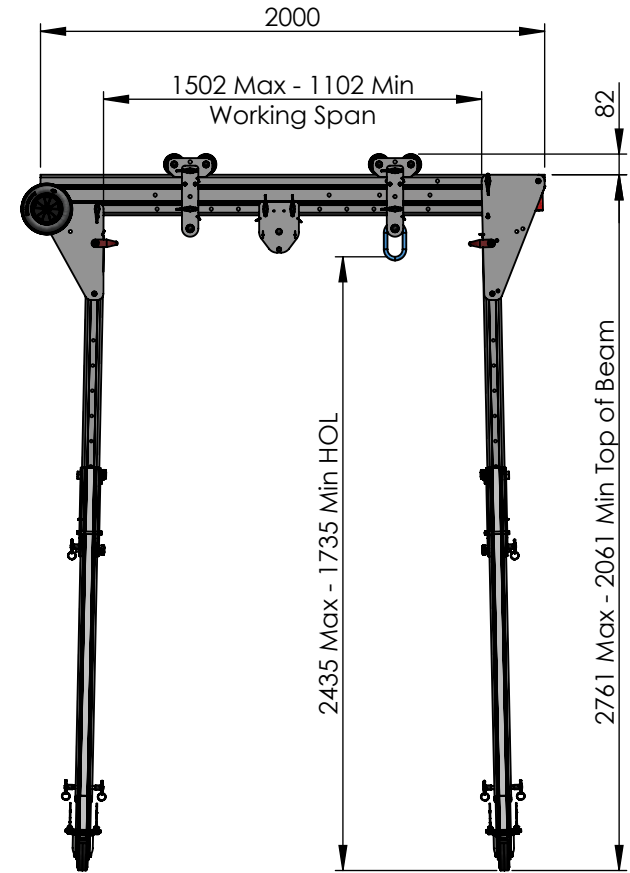
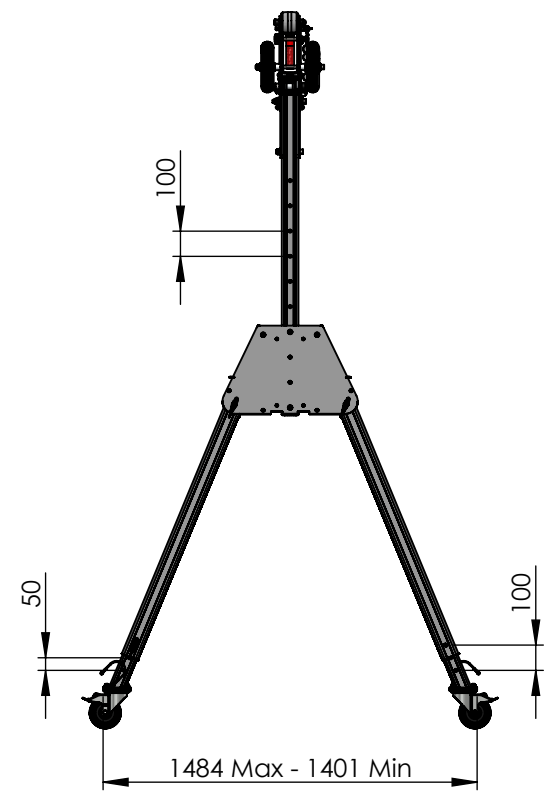
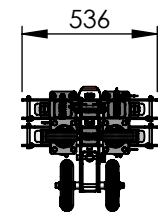

DO NOT SCALE DRAWING

REVISION **02**



Reid Lifting Limited. Unit 1  
Wyeview, Newhouse Farm Ind. Est.,  
Chepstow, Monmouthshire.  
NP16 6UD, UK  
Tel +44(0) 1291 620796  
Fax +44(0) 1291 626490  
[www.reidlifting.com](http://www.reidlifting.com)  
[enquiries@reidlifting.com](mailto:enquiries@reidlifting.com)

	NAME	DATE	FINISH:
DRAWN	SS	01/07/2021	Anodised
CHK'D			MATERIAL:
APPV'D	CM	11/11/2022	Aluminium Alloy
<small>ALL COPYRIGHT AND DESIGN RIGHT SUBSISTING IN THIS DOCUMENT IS THE PROPERTY OF REID LIFTING LIMITED AND MAY NOT BE REPRODUCED WITHOUT REID LIFTING'S CONSENT. THIS DOCUMENT AND THE INFORMATION CONTAINED WITHIN IT IS CONFIDENTIAL AND MAY NOT BE DISCLOSED TO ANY THIRD PARTY NOR USED FOR ANY UNAUTHORISED PURPOSE WITHOUT REID LIFTING'S CONSENT</small>			
UNLESS OTHERWISE SPECIFIED:			
DIMENSIONS ARE IN MILLIMETERS			

TITLE:	<b>Porta-Gantry Rapide Medium Frame WLL1000kg 2000mm Beam - Castors</b>	
DWG NO.	<b>PGR1TM20J</b>	A4
Estimated Weight:	56kg	1:30
		SHEET 1 OF 2

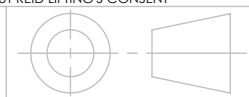

## General Specification

- Maximum rated capacity for goods lifting - 1000kg
- Maximum rated capacity for personnel lifting - 500kg
- Beam deflection at maximum rated capacity of 1000kg - 10-20 mm at centre of span
- Maximum castor surface pressure at full load - 16.73MPa
- Assembled gantry weight (excluding trolleys) - 56kg
- All welding to BS EN ISO 15614-2: 2005 by certified welders.
- For further details and assembly information refer to Operations and Maintenance Manual for Porta Gantry Rapide Product. (available at [www.reidlifting.com](http://www.reidlifting.com))

## Fall Protection Standards

- Certified to EN795:2012 Type B & supplied under PPE Regulation 2016/425
- Notified Body Witness tested to the requirements of PD CEN/TS16415:2013 for 3 persons
- Exceeds the requirements of IRATA ICOP & BS7985 (15kN MBL)

## Materials & Finishes

- Frame and beam - 6082 T6 Aluminium alloy. Anodised.
- Castors - Steel. Bright Zinc Plated.
- Castor Wheels & Rollers - Nylon & Rubber
- Fixings - Steel. Grade 12:9. Bright Zinc Plated.

Note: Trolleys & Sheave Carrier shown in system as a reference



DO NOT SCALE DRAWING

REVISION **02**



Reid Lifting Limited. Unit 1  
Wyeview, Newhouse Farm Ind. Est.,  
Chepstow, Monmouthshire.  
NP16 6UD, UK

Tel +44(0)1291 620796  
Fax: +44(0)1291 626490

[www.reidlifting.com](http://www.reidlifting.com)

[enquiries@reidlifting.com](mailto:enquiries@reidlifting.com)

	NAME	DATE
DRAWN	SS	01/07/2021
CHK'D		
APP'VD	CM	11/11/2022

UNLESS OTHERWISE SPECIFIED:  
DIMENSIONS ARE IN MILLIMETERS

ALL COPYRIGHT AND DESIGN RIGHT SUBSISTING IN THIS DOCUMENT IS THE PROPERTY OF REID LIFTING LIMITED AND MAY NOT BE REPRODUCED WITHOUT REID LIFTING'S CONSENT. THIS DOCUMENT AND THE INFORMATION CONTAINED WITHIN IT IS CONFIDENTIAL AND MAY NOT BE DISCLOSED TO ANY THIRD PARTY NOR USED FOR ANY UNAUTHORISED PURPOSE WITHOUT REID LIFTING'S CONSENT

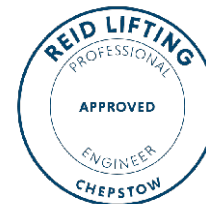

TITLE: **Porta-Gantry Rapide  
Medium Frame WLL1000kg  
2000mm Beam - Castors**

DWG NO.

**PGR1TM20J**

A4

Estimated Weight: 56kg

1:25

SHEET 2 OF 2

1 2 3 4 5 6

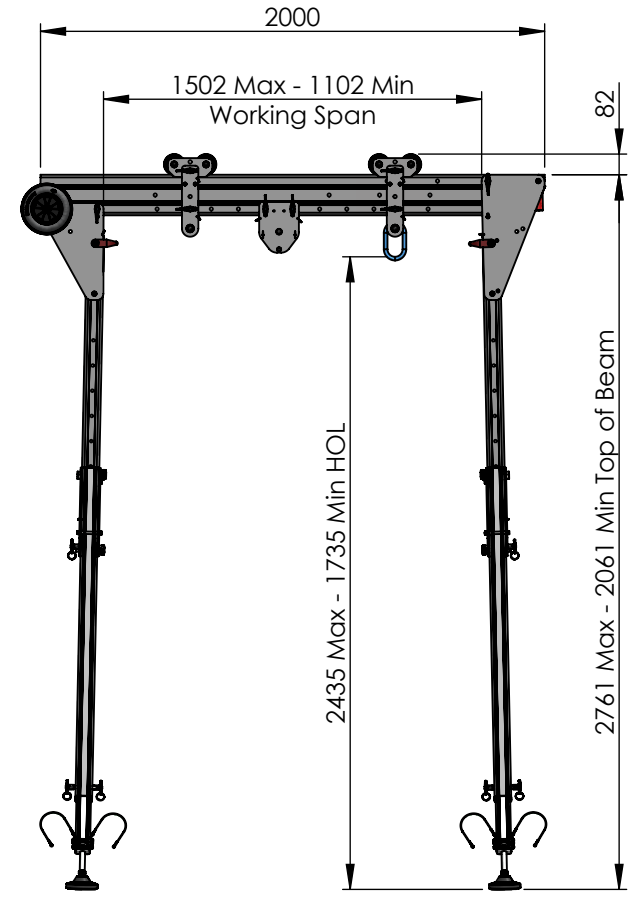
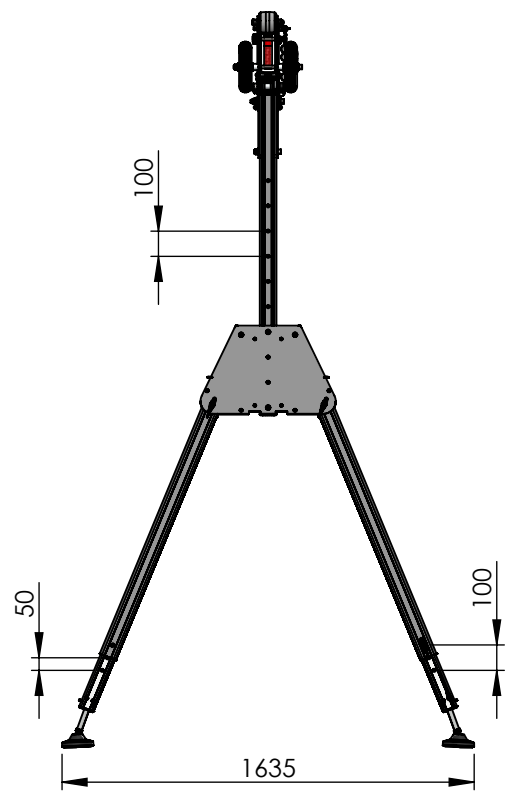
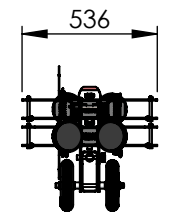
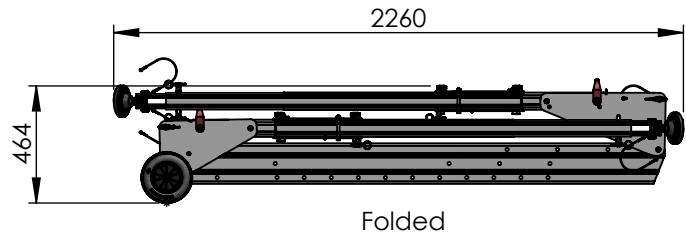

DO NOT SCALE DRAWING

REVISION **02**



Reid Lifting Limited. Unit 1  
Wyeview, Newhouse Farm Ind. Est.,  
Chepstow, Monmouthshire.  
NP16 6UD, UK  
Tel +44(0) 1291 620796  
Fax +44(0) 1291 626490  
[www.reidlifting.com](http://www.reidlifting.com)  
[enquiries@reidlifting.com](mailto:enquiries@reidlifting.com)

	NAME	DATE	FINISH:
DRAWN	SS	05/07/2021	Anodised
CHK'D			MATERIAL:
APPV'D	CM	11/11/2022	Aluminium Alloy
<small>ALL COPYRIGHT AND DESIGN RIGHT SUBSISTING IN THIS DOCUMENT IS THE PROPERTY OF REID LIFTING LIMITED AND MAY NOT BE REPRODUCED WITHOUT REID LIFTING'S CONSENT. THIS DOCUMENT AND THE INFORMATION CONTAINED WITHIN IT IS CONFIDENTIAL AND MAY NOT BE DISCLOSED TO ANY THIRD PARTY NOR USED FOR ANY UNAUTHORISED PURPOSE WITHOUT REID LIFTING'S CONSENT</small>			
UNLESS OTHERWISE SPECIFIED:			
DIMENSIONS ARE IN MILLIMETERS			

TITLE:	<b>Porta-Gantry Rapide Medium Frame WLL1000kg 2000mm Beam - Adjustable Feet</b>	
DWG NO.	<b>PGR1TM20K</b>	A4
Estimated Weight:	56kg	1:30
		SHEET 1 OF 2

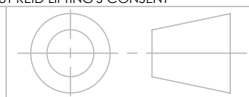

## General Specification

- Maximum rated capacity for goods lifting - 1000kg
- Maximum rated capacity for personnel lifting - 500kg
- Beam deflection at maximum rated capacity of 1000kg - 10-20 mm at centre of span
- Maximum Foot Pad surface pressure at full load - 0.53MPa
- Assembled gantry weight (excluding trolleys) - 56kg
- All welding to BS EN ISO 15614-2: 2005 by certified welders.
- For further details and assembly information refer to Operations and Maintenance Manual for Porta Gantry Rapide Product. (available at [www.reidlifting.com](http://www.reidlifting.com))

## Fall Protection Standards

- Certified to EN795:2012 Type B & supplied under PPE Regulation 2016/425
- Notified Body Witness tested to the requirements of PD CEN/TS16415:2013 for 3 persons
- Exceeds the requirements of IRATA ICOP & BS7985 (15kN MBL)

## Materials & Finishes

- Frame and beam - 6082 T6 Aluminium alloy. Anodised.
- Castors - Steel. Bright Zinc Plated.
- Castor Wheels & Rollers - Nylon & Rubber
- Fixings - Steel. Grade 12:9. Bright Zinc Plated.

Note: Trolleys & Sheave Carrier shown in system as a reference



DO NOT SCALE DRAWING

REVISION

**02**



Reid Lifting Limited. Unit 1  
Wyeview, Newhouse Farm Ind. Est.,  
Chepstow, Monmouthshire.  
NP16 6UD, UK

Tel +44(0)1291 620796  
Fax: +44(0)1291 626490

[www.reidlifting.com](http://www.reidlifting.com)

[enquiries@reidlifting.com](mailto:enquiries@reidlifting.com)

	NAME	DATE
DRAWN	SS	05/07/2021
CHK'D		
APP'VD	CM	11/11/2022

UNLESS OTHERWISE SPECIFIED:  
DIMENSIONS ARE IN MILLIMETERS

ALL COPYRIGHT AND DESIGN RIGHT SUBSISTING IN THIS DOCUMENT IS THE PROPERTY OF REID LIFTING LIMITED AND MAY NOT BE REPRODUCED WITHOUT REID LIFTING'S CONSENT. THIS DOCUMENT AND THE INFORMATION CONTAINED WITHIN IT IS CONFIDENTIAL AND MAY NOT BE DISCLOSED TO ANY THIRD PARTY NOR USED FOR ANY UNAUTHORISED PURPOSE WITHOUT REID LIFTING'S CONSENT



TITLE:

**Porta-Gantry Rapide Medium  
Frame WLL1000kg 2000mm  
Beam - Adjustable Feet**

DWG NO.

**PGR1TM20K**

A4

Estimated Weight: 56kg

1:25

SHEET 2 OF 2

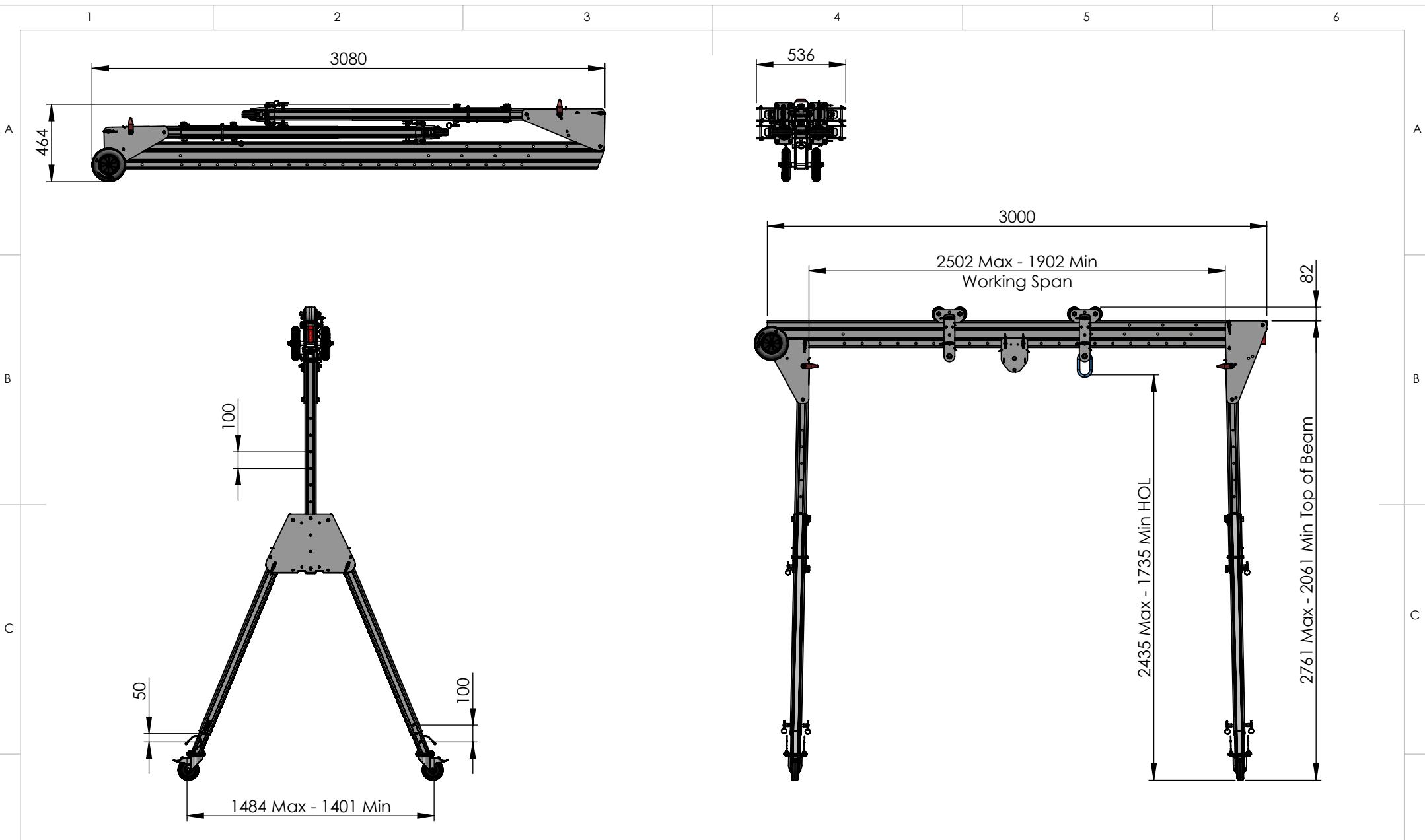

DO NOT SCALE DRAWING

REVISION **02**



Reid Lifting Limited. Unit 1  
 Wyeview, Newhouse Farm Ind. Est.,  
 Chepstow, Monmouthshire.  
 NP16 6UD, UK  
 Tel +44(0) 1291 620796  
 Fax +44(0) 1291 626490

[www.reidlifting.com](http://www.reidlifting.com)

[enquiries@reidlifting.com](mailto:enquiries@reidlifting.com)

	NAME	DATE	FINISH:
DRAWN	SS	28/06/2021	Anodised
CHK'D			MATERIAL:
APPV'D	CM	11/11/2022	Aluminium Alloy
<small>ALL COPYRIGHT AND DESIGN RIGHT SUBSISTING IN THIS DOCUMENT IS THE PROPERTY OF REID LIFTING LIMITED AND MAY NOT BE REPRODUCED WITHOUT REID LIFTING'S CONSENT. THIS DOCUMENT AND THE INFORMATION CONTAINED WITHIN IT IS CONFIDENTIAL AND MAY NOT BE DISCLOSED TO ANY THIRD PARTY NOR USED FOR ANY UNAUTHORISED PURPOSE WITHOUT REID LIFTING'S CONSENT</small>			
<small>UNLESS OTHERWISE SPECIFIED:            DIMENSIONS ARE IN MILLIMETERS</small>			

TITLE: **Porta-Gantry Rapide  
 Medium Frame WLL1000kg  
 3000mm Beam - Castors**

DWG NO. **PGR1TM30J** A4

Estimated Weight: 60kg 1:30 SHEET 1 OF 2

## General Specification

- Maximum rated capacity for goods lifting - 1000kg
- Maximum rated capacity for personnel lifting - 500kg
- Beam deflection at maximum rated capacity of 1000kg - 20-30 mm at centre of span
- Maximum castor surface pressure at full load - 16.80MPa
- Assembled gantry weight (excluding trolleys) - 60kg
- All welding to BS EN ISO 15614-2: 2005 by certified welders.
- For further details and assembly information refer to Operations and Maintenance Manual for Porta Gantry Rapide Product. (available at [www.reidlifting.com](http://www.reidlifting.com))

## Fall Protection Standards

- Certified to EN795:2012 Type B & supplied under PPE Regulation 2016/425
- Exceeds the requirements of IRATA ICOP & BS7985 (15kN MBL)

## Materials & Finishes

- Frame and beam - 6082 T6 Aluminium alloy. Anodised.
- Castors - Steel. Bright Zinc Plated.
- Castor Wheels & Rollers - Nylon & Rubber
- Fixings - Steel. Grade 12:9. Bright Zinc Plated.

Note: Trolleys & Sheave Carrier shown in system as a reference



DO NOT SCALE DRAWING

REVISION **02**

**REID**  
**LIFTING**

Reid Lifting Limited. Unit 1  
Wyeview, Newhouse Farm Ind. Est.,  
Chepstow, Monmouthshire.  
NP16 6UD, UK

Tel +44(0)1291 620796  
Fax: +44(0)1291 626490

[www.reidlifting.com](http://www.reidlifting.com)

[enquiries@reidlifting.com](mailto:enquiries@reidlifting.com)

	NAME	DATE
DRAWN	SS	28/06/2021
CHK'D		
APP'VD	CM	11/11/2022

UNLESS OTHERWISE SPECIFIED:  
DIMENSIONS ARE IN MILLIMETERS

ALL COPYRIGHT AND DESIGN RIGHT SUBSISTING IN THIS DOCUMENT IS THE PROPERTY OF REID LIFTING LIMITED AND MAY NOT BE REPRODUCED WITHOUT REID LIFTING'S CONSENT. THIS DOCUMENT AND THE INFORMATION CONTAINED WITHIN IT IS CONFIDENTIAL AND MAY NOT BE DISCLOSED TO ANY THIRD PARTY NOR USED FOR ANY UNAUTHORISED PURPOSE WITHOUT REID LIFTING'S CONSENT



TITLE: **Porta-Gantry Rapide  
Medium Frame WLL1000kg  
3000mm Beam - Castors**

DWG NO.

**PGR1TM30J**

A4

Estimated Weight: 60kg

1:45

SHEET 2 OF 2

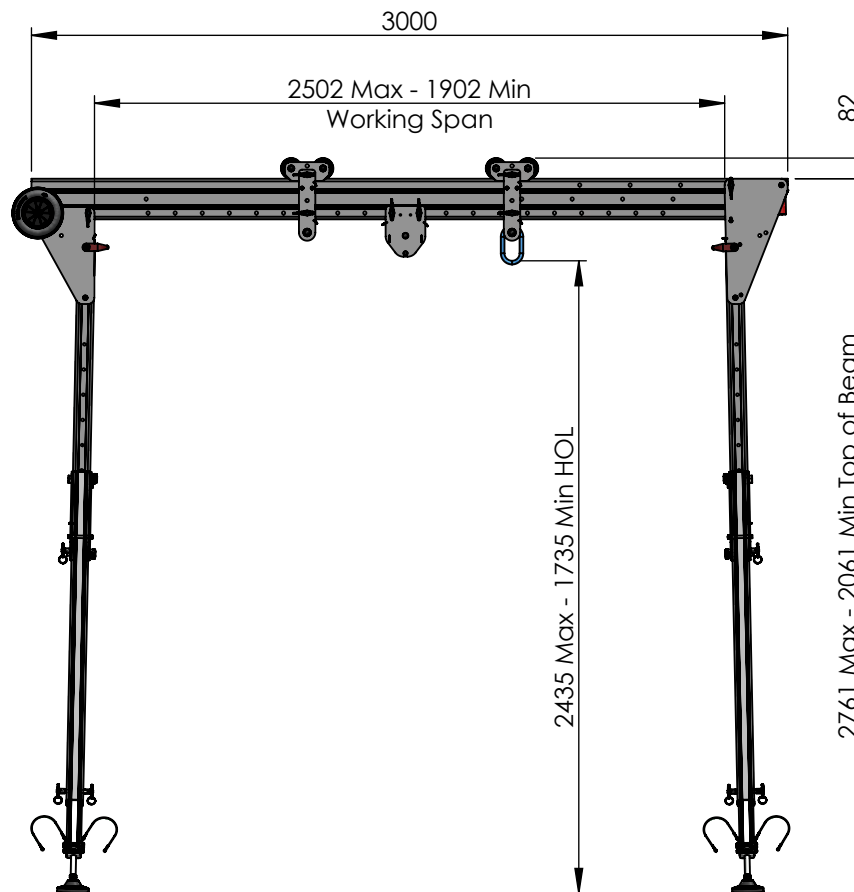
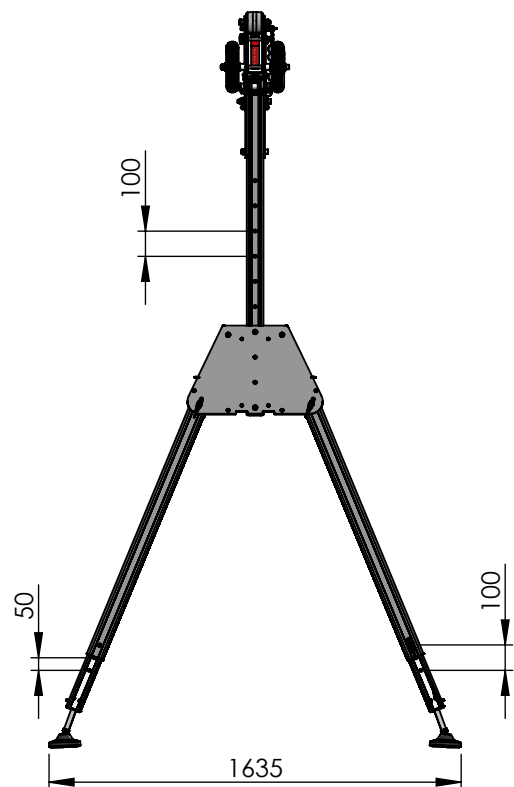
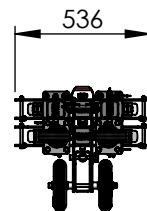
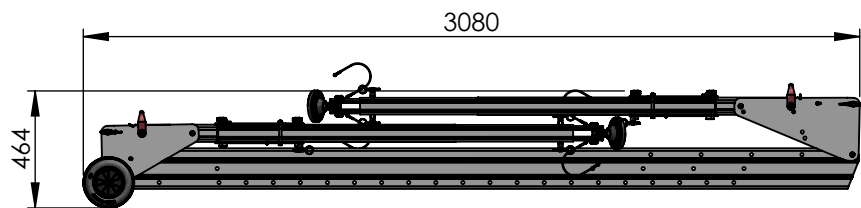

DO NOT SCALE DRAWING

REVISION **02**



Reid Lifting Limited. Unit 1  
Wyeview, Newhouse Farm Ind. Est.,  
Chepstow, Monmouthshire.  
NP16 6UD, UK  
Tel +44(0) 1291 620796  
Fax +44(0) 1291 626490

[www.reidlifting.com](http://www.reidlifting.com)

[enquiries@reidlifting.com](mailto:enquiries@reidlifting.com)

	NAME	DATE	FINISH:
DRAWN	SS	05/07/2021	Anodised
CHK'D			MATERIAL:
APPV'D	CM	11/11/2022	Aluminium Alloy
<small>ALL COPYRIGHT AND DESIGN RIGHT SUBSISTING IN THIS DOCUMENT IS THE PROPERTY OF REID LIFTING LIMITED AND MAY NOT BE REPRODUCED WITHOUT REID LIFTING'S CONSENT. THIS DOCUMENT AND THE INFORMATION CONTAINED WITHIN IT IS CONFIDENTIAL AND MAY NOT BE DISCLOSED TO ANY THIRD PARTY NOR USED FOR ANY UNAUTHORISED PURPOSE WITHOUT REID LIFTING'S CONSENT</small>			
UNLESS OTHERWISE SPECIFIED:			
DIMENSIONS ARE IN MILLIMETERS			

TITLE:

**Porta-Gantry Rapide Medium  
Frame WLL1000kg 3000mm  
Beam - Adjustable Feet**

DWG NO.

**PGR1TM30K**

A4

Estimated Weight: 60kg

1:30

SHEET 1 OF 2

## General Specification

- Maximum rated capacity for goods lifting - 1000kg
- Maximum rated capacity for personnel lifting - 500kg
- Beam deflection at maximum rated capacity of 1000kg - 20-30 mm at centre of span
- Maximum Foot Pad surface pressure at full load - 0.53 MPa
- Assembled gantry weight (excluding trolleys) - 60kg
- All welding to BS EN ISO 15614-2: 2005 by certified welders.
- For further details and assembly information refer to Operations and Maintenance Manual for Porta Gantry Rapide Product. (available at [www.reidlifting.com](http://www.reidlifting.com))

## Fall Protection Standards

- Certified to EN795:2012 Type B & supplied under PPE Regulation 2016/425
- Notified Body Witness tested to the requirements of PD CEN/TS16415:2013 for 3 persons
- Exceeds the requirements of IRATA ICOP & BS7985 (15kN MBL)

## Materials & Finishes

- Frame and beam - 6082 T6 Aluminium alloy. Anodised.
- Castors - Steel. Bright Zinc Plated.
- Castor Wheels & Rollers - Nylon & Rubber
- Fixings - Steel. Grade 12:9. Bright Zinc Plated.

Note: Trolleys & Sheave Carrier shown in system as a reference



DO NOT SCALE DRAWING

REVISION

**02**



Reid Lifting Limited. Unit 1  
Wyeview, Newhouse Farm Ind. Est.,  
Chepstow, Monmouthshire.  
NP16 6UD, UK

Tel +44(0)1291 620796  
Fax: +44(0)1291 626490

[www.reidlifting.com](http://www.reidlifting.com)

[enquiries@reidlifting.com](mailto:enquiries@reidlifting.com)

	NAME	DATE
DRAWN	SS	05/07/2021
CHK'D		
APP'VD	CM	11/11/2022

UNLESS OTHERWISE SPECIFIED:  
DIMENSIONS ARE IN MILLIMETERS

ALL COPYRIGHT AND DESIGN RIGHT SUBSISTING IN THIS DOCUMENT IS THE PROPERTY OF REID LIFTING LIMITED AND MAY NOT BE REPRODUCED WITHOUT REID LIFTING'S CONSENT. THIS DOCUMENT AND THE INFORMATION CONTAINED WITHIN IT IS CONFIDENTIAL AND MAY NOT BE DISCLOSED TO ANY THIRD PARTY NOR USED FOR ANY UNAUTHORISED PURPOSE WITHOUT REID LIFTING'S CONSENT



TITLE:

**Porta-Gantry Rapide Medium  
Frame WLL1000kg 3000mm  
Beam - Adjustable Feet**

DWG NO.

**PGR1TM30K**

A4

Estimated Weight: 60kg

1:45

SHEET 2 OF 2

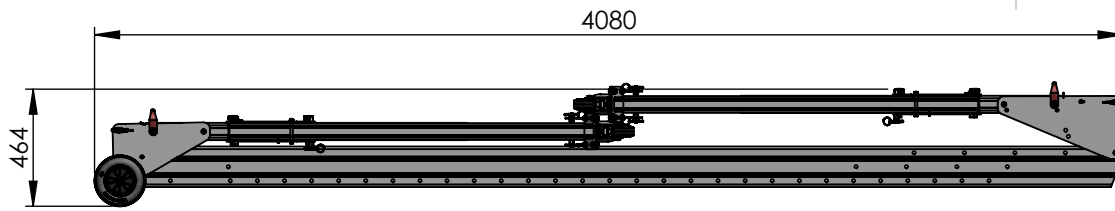

Folded

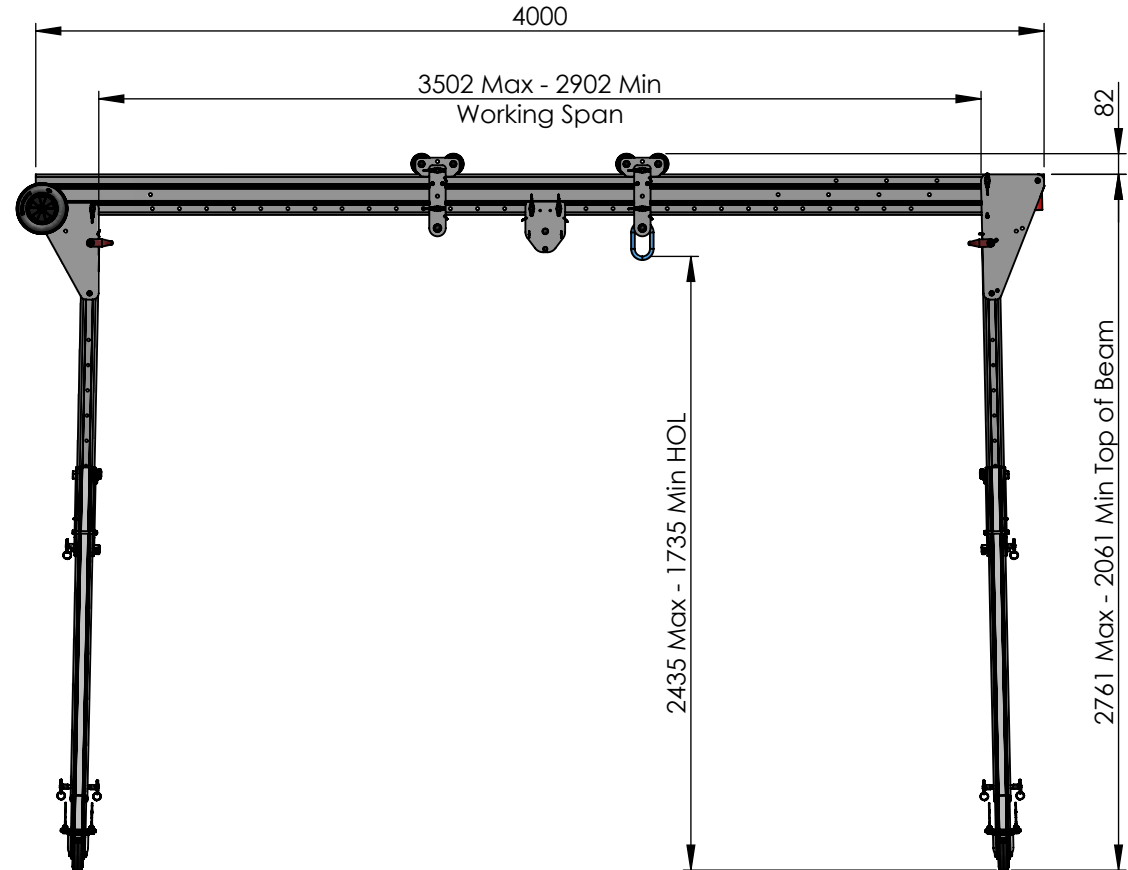
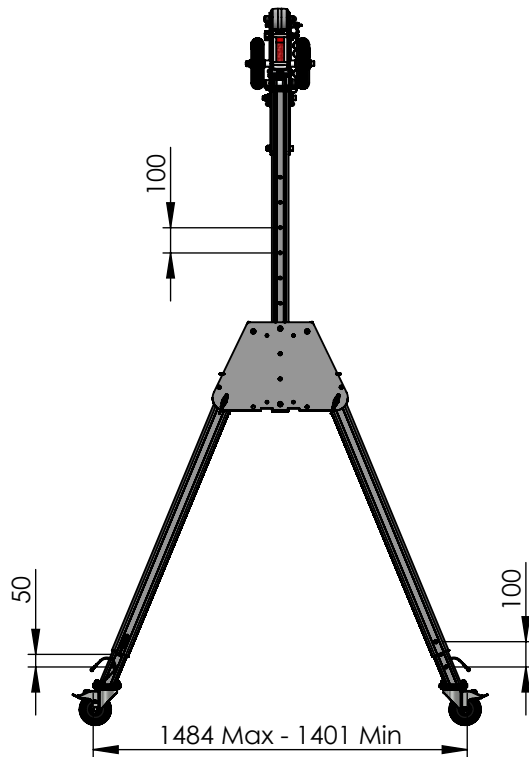
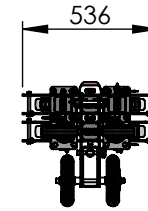

DO NOT SCALE DRAWING

REVISION **03**



Reid Lifting Limited. Unit 1  
Wyeview, Newhouse Farm Ind. Est.,  
Chepstow, Monmouthshire.  
NP16 6UD, UK  
Tel +44(0) 1291 620796  
Fax +44(0) 1291 626490

[www.reidlifting.com](http://www.reidlifting.com)

[enquiries@reidlifting.com](mailto:enquiries@reidlifting.com)

	NAME	DATE	FINISH:
DRAWN	SS	01/07/2021	Anodised
CHK'D			MATERIAL:
APPV'D	CM	11/11/2022	Aluminium Alloy
ALL COPYRIGHT AND DESIGN RIGHT SUBSISTING IN THIS DOCUMENT IS THE PROPERTY OF REID LIFTING LIMITED AND MAY NOT BE REPRODUCED WITHOUT REID LIFTING'S CONSENT. THIS DOCUMENT AND THE INFORMATION CONTAINED WITHIN IT IS CONFIDENTIAL AND MAY NOT BE DISCLOSED TO ANY THIRD PARTY NOR USED FOR ANY UNAUTHORISED PURPOSE WITHOUT REID LIFTING'S CONSENT			
UNLESS OTHERWISE SPECIFIED:			
DIMENSIONS ARE IN MILLIMETERS			

TITLE: **Porta-Gantry Rapide  
Medium Frame WLL1000kg  
4000mm Beam - Castors**

DWG NO. **PGR1TM40J** A4

Estimated Weight: 65kg 1:30 SHEET 1 OF 2

## General Specification

- Maximum rated capacity for goods lifting - 1000kg
- Maximum rated capacity for personnel lifting - 500kg
- Beam deflection at maximum rated capacity of 1000kg - 30-45 mm at centre of span
- Maximum castor surface pressure at full load - 16.89MPa
- Assembled gantry weight (excluding trolleys) - 65kg
- All welding to BS EN ISO 15614-2: 2005 by certified welders.
- For further details and assembly information refer to Operations and Maintenance Manual for Porta Gantry Rapide Product. (available at [www.reidlifting.com](http://www.reidlifting.com))

## Fall Protection Standards

- Certified to EN795:2012 Type B & supplied under PPE Regulation 2016/425
- Notified Body Witness tested to the requirements of PD CEN/TS16415:2013 for 3 persons
- Exceeds the requirements of IRATA ICOP & BS7985 (15kN MBL)

## Materials & Finishes

- Frame and beam - 6082 T6 Aluminium alloy. Anodised.
- Castors - Steel. Bright Zinc Plated.
- Castor Wheels & Rollers - Nylon & Rubber
- Fixings - Steel. Grade 12:9. Bright Zinc Plated.

Note: Trolleys & Sheave Carrier shown in system as a reference



DO NOT SCALE DRAWING

REVISION

**03**

**REID**  
**LIFTING**

Reid Lifting Limited. Unit 1  
Wyeview, Newhouse Farm Ind. Est.,  
Chepstow, Monmouthshire.  
NP16 6UD, UK

Tel +44(0)1291 620796  
Fax: +44(0)1291 626490

[www.reidlifting.com](http://www.reidlifting.com)

[enquiries@reidlifting.com](mailto:enquiries@reidlifting.com)

	NAME	DATE
DRAWN	SS	01/07/2021
CHK'D		
APP'VD	CM	11/11/2022

UNLESS OTHERWISE SPECIFIED:  
DIMENSIONS ARE IN MILLIMETERS

ALL COPYRIGHT AND DESIGN RIGHT SUBSISTING IN THIS DOCUMENT IS THE PROPERTY OF REID LIFTING LIMITED AND MAY NOT BE REPRODUCED WITHOUT REID LIFTING'S CONSENT. THIS DOCUMENT AND THE INFORMATION CONTAINED WITHIN IT IS CONFIDENTIAL AND MAY NOT BE DISCLOSED TO ANY THIRD PARTY NOR USED FOR ANY UNAUTHORISED PURPOSE WITHOUT REID LIFTING'S CONSENT



TITLE:

**Porta-Gantry Rapide  
Medium Frame WLL1000kg  
4000mm Beam - Castors**

DWG NO.

**PGR1TM40J**

A4

Estimated Weight: 65kg

1:30

SHEET 2 OF 2

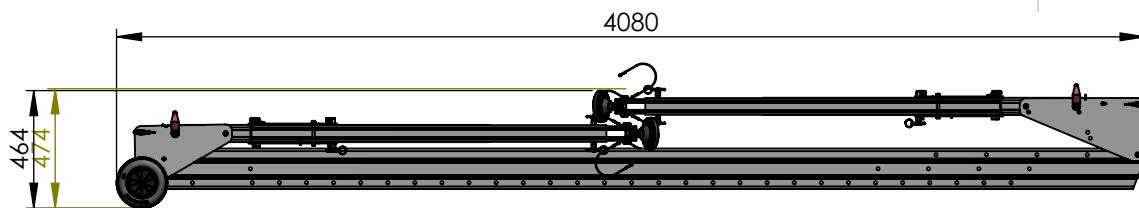

Folded

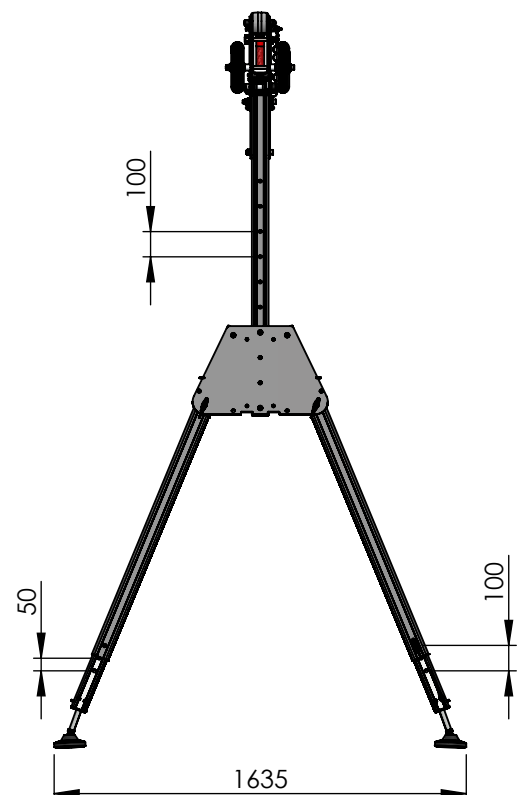
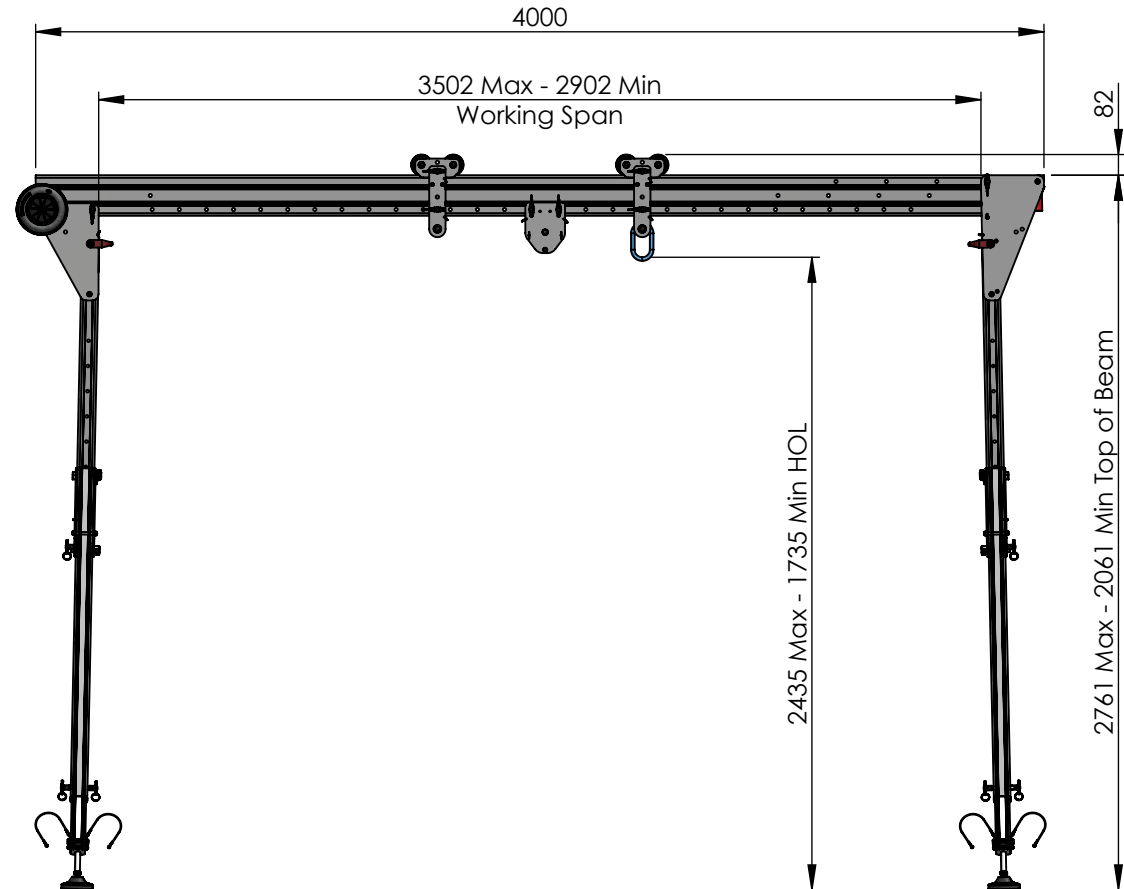
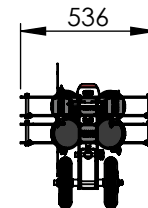

DO NOT SCALE DRAWING

REVISION **02**



Reid Lifting Limited. Unit 1  
Wyeview, Newhouse Farm Ind. Est.,  
Chepstow, Monmouthshire.  
NP16 6UD, UK  
Tel +44(0) 1291 620796  
Fax +44(0) 1291 626490

[www.reidlifting.com](http://www.reidlifting.com)

[enquiries@reidlifting.com](mailto:enquiries@reidlifting.com)

	NAME	DATE	FINISH:
DRAWN	SS	05/07/2021	Anodised
CHK'D			MATERIAL:
APPV'D	CM	11/11/2022	Aluminium Alloy
<small>ALL COPYRIGHT AND DESIGN RIGHT SUBSISTING IN THIS DOCUMENT IS THE PROPERTY OF REID LIFTING LIMITED AND MAY NOT BE REPRODUCED WITHOUT REID LIFTING'S CONSENT. THIS DOCUMENT AND THE INFORMATION CONTAINED WITHIN IT IS CONFIDENTIAL AND MAY NOT BE DISCLOSED TO ANY THIRD PARTY NOR USED FOR ANY UNAUTHORISED PURPOSE WITHOUT REID LIFTING'S CONSENT</small>			
UNLESS OTHERWISE SPECIFIED:			
DIMENSIONS ARE IN MILLIMETERS			

TITLE:	<b>Porta-Gantry Rapide Medium Frame WLL1000kg 4000mm Beam - Adjustable Feet</b>
DWG NO.	<b>PGR1TM40K</b>
Estimated Weight:	65kg
	1:30
	A4
	SHEET 1 OF 2



## General Specification

- Maximum rated capacity for goods lifting - 1000kg
- Maximum rated capacity for personnel lifting - 500kg
- Beam deflection at maximum rated capacity of 1000kg - 30-45 mm at centre of span
- Maximum foot pad surface pressure at full load - 0.53 MPa
- Assembled gantry weight (excluding trolleys) - 65kg
- All welding to BS EN ISO 15614-2: 2005 by certified welders.
- For further details and assembly information refer to Operations and Maintenance Manual for Porta Gantry Rapide Product. (available at [www.reidlifting.com](http://www.reidlifting.com))

## Fall Protection Standards

- Certified to EN795:2012 Type B & supplied under PPE Regulation 2016/425
- Notified Body Witness tested to the requirements of PD CEN/TS16415:2013 for 3 persons
- Exceeds the requirements of IRATA ICOP & BS7985 (15kN MBL)

## Materials & Finishes

- Frame and beam - 6082 T6 Aluminium alloy. Anodised.
- Castors - Steel. Bright Zinc Plated.
- Castor Wheels & Rollers - Nylon & Rubber
- Fixings - Steel. Grade 12:9. Bright Zinc Plated.

Note: Trolleys & Sheave Carrier shown in system as a reference



Approved

DO NOT SCALE DRAWING

REVISION

02



Reid Lifting Limited. Unit 1  
Wyeview, Newhouse Farm Ind. Est.,  
Chepstow, Monmouthshire.  
NP16 6UD, UK

Tel +44(0)1291 620796  
Fax: +44(0)1291 626490

[www.reidlifting.com](http://www.reidlifting.com)

[enquiries@reidlifting.com](mailto:enquiries@reidlifting.com)

	NAME	DATE
DRAWN	SS	05/07/2021
CHK'D		
APP'VD	CM	11/11/2022

UNLESS OTHERWISE SPECIFIED:  
DIMENSIONS ARE IN MILLIMETERS

ALL COPYRIGHT AND DESIGN RIGHT SUBSISTING IN THIS DOCUMENT IS THE PROPERTY OF REID LIFTING LIMITED AND MAY NOT BE REPRODUCED WITHOUT REID LIFTING'S CONSENT. THIS DOCUMENT AND THE INFORMATION CONTAINED WITHIN IT IS CONFIDENTIAL AND MAY NOT BE DISCLOSED TO ANY THIRD PARTY NOR USED FOR ANY UNAUTHORISED PURPOSE WITHOUT REID LIFTING'S CONSENT



TITLE:

**Porta-Gantry Rapide Medium  
Frame WLL1000kg 4000mm  
Beam - Adjustable Feet**

DWG NO.

**PGR1TM40K**

A4

Estimated Weight: 65kg

1:30

SHEET 2 OF 2

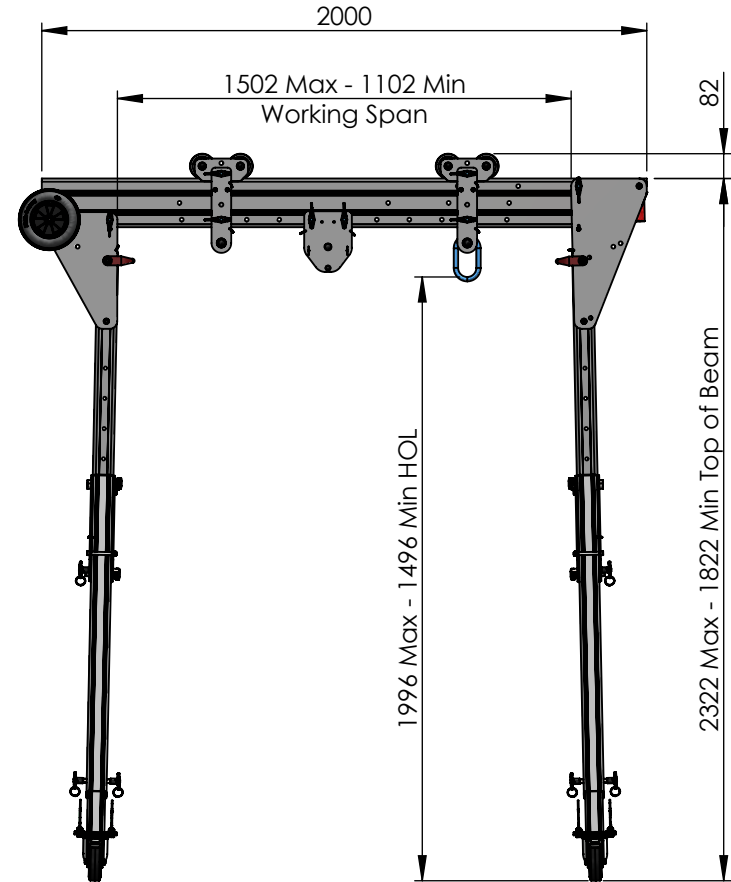
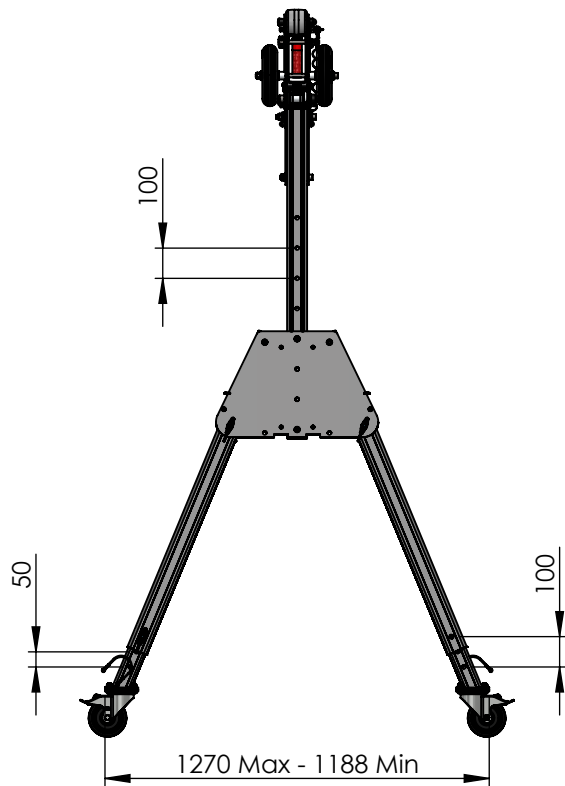
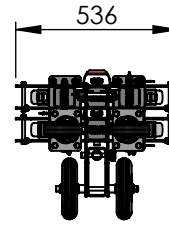
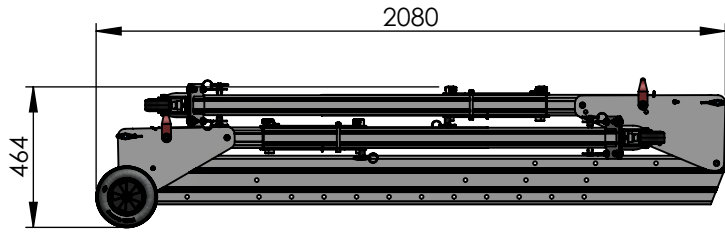

DO NOT SCALE DRAWING

REVISION 03



Reid Lifting Limited. Unit 1  
Wyeview, Newhouse Farm Ind. Est.,  
Chepstow, Monmouthshire.  
NP16 6UD, UK  
Tel +44(0) 1291 620796  
Fax +44(0) 1291 626490

[www.reidlifting.com](http://www.reidlifting.com)

[enquiries@reidlifting.com](mailto:enquiries@reidlifting.com)

	NAME	DATE	FINISH:
DRAWN	SS	01/07/2021	Anodised
CHK'D			MATERIAL:
APPV'D	AB	18/08/2023	Aluminium Alloy
<small>ALL COPYRIGHT AND DESIGN RIGHT SUBSISTING IN THIS DOCUMENT IS THE PROPERTY OF REID LIFTING LIMITED AND MAY NOT BE REPRODUCED WITHOUT REID LIFTING'S CONSENT. THIS DOCUMENT AND THE INFORMATION CONTAINED WITHIN IT IS CONFIDENTIAL AND MAY NOT BE DISCLOSED TO ANY THIRD PARTY NOR USED FOR ANY UNAUTHORISED PURPOSE WITHOUT REID LIFTING'S CONSENT</small>			
<small>UNLESS OTHERWISE SPECIFIED: DIMENSIONS ARE IN MILLIMETERS</small>			

TITLE: Porta-Gantry Rapide Standard  
Frame WLL1000kg 2000mm  
Beam - Castors

DWG NO. PGR1TS20J A4

Estimated Weight: 52kg 1:25 SHEET 1 OF 2

## General Specification

- Maximum rated capacity for goods lifting - 1000kg
- Maximum rated capacity for personnel lifting - 500kg
- Beam deflection at maximum rated capacity of 1000kg - 10-20 mm at centre of span
- Maximum castor surface pressure at full load - 15.48 MPa
- Assembled gantry weight (excluding trolleys) - 52kg
- All welding to BS EN ISO 15614-2: 2005 by certified welders.
- For further details and assembly information refer to Operations and Maintenance Manual for Porta Gantry Rapide Product. (available at [www.reidlifting.com](http://www.reidlifting.com))

## Fall Protection Standards

- Certified to EN795:2012 Type B & supplied under PPE Regulation 2016/425
- Notified Body Witness tested to the requirements of PD CEN/TS16415:2013 for 3 persons
- Exceeds the requirements of IRATA ICOP & BS7985 (15kN MBL)

## Materials & Finishes

- Frame and beam - 6082 T6 Aluminium alloy. Anodised.
- Castors - Steel. Bright Zinc Plated.
- Castor Wheels & Rollers - Nylon & Rubber
- Fixings - Steel. Grade 12:9. Bright Zinc Plated.

Note: Trolleys & Sheave Carrier shown in system as a reference



DO NOT SCALE DRAWING

REVISION 03

	NAME	DATE
DRAWN	SS	01/07/2021
CHK'D		
APP'VD	AB	18/08/2023

UNLESS OTHERWISE SPECIFIED:  
DIMENSIONS ARE IN MILLIMETERS

ALL COPYRIGHT AND DESIGN RIGHT SUBSISTING IN THIS DOCUMENT IS THE PROPERTY OF REID LIFTING LIMITED AND MAY NOT BE REPRODUCED WITHOUT REID LIFTING'S CONSENT. THIS DOCUMENT AND THE INFORMATION CONTAINED WITHIN IT IS CONFIDENTIAL AND MAY NOT BE DISCLOSED TO ANY THIRD PARTY NOR USED FOR ANY UNAUTHORISED PURPOSE WITHOUT REID LIFTING'S CONSENT



TITLE: Porta-Gantry Rapide Standard Frame WLL1000kg 2000mm Beam - Castors

DWG NO.

PGR1TS20J

A4

Estimated Weight: 52kg

1:20

SHEET 2 OF 2



Reid Lifting Limited. Unit 1  
Wyeview, Newhouse Farm Ind. Est.,  
Chepstow, Monmouthshire.  
NP16 6UD, UK  
Tel +44(0)1291 620796  
Fax: +44(0)1291 626490

[www.reidlifting.com](http://www.reidlifting.com)

[enquiries@reidlifting.com](mailto:enquiries@reidlifting.com)

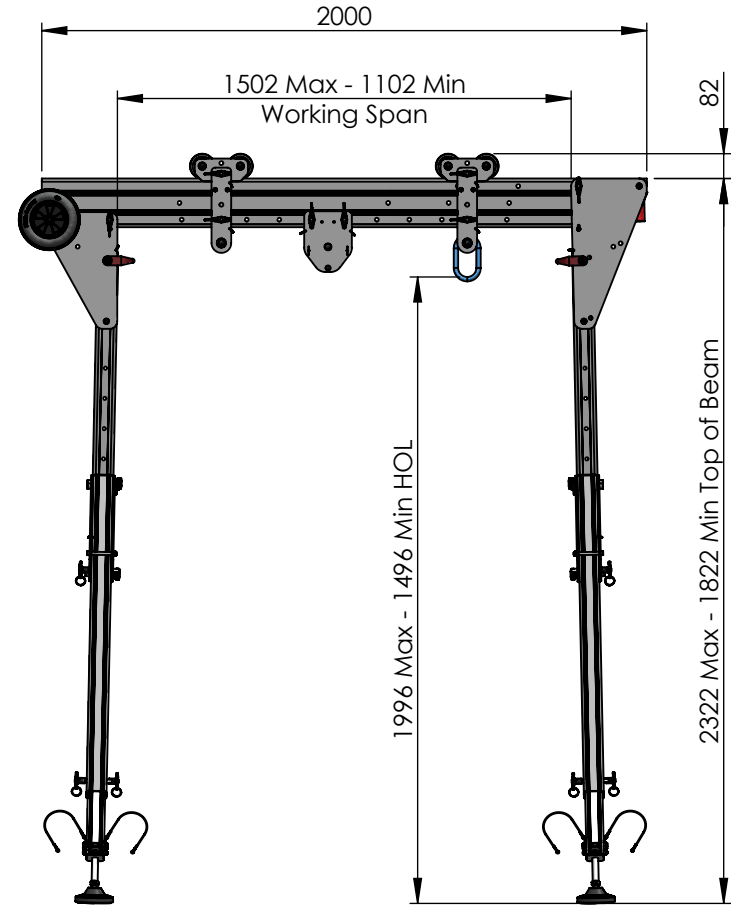
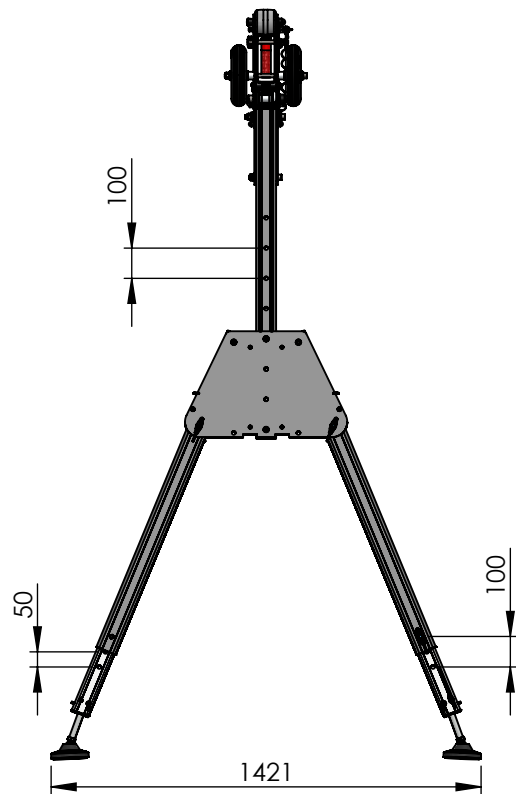
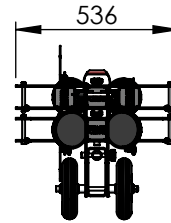
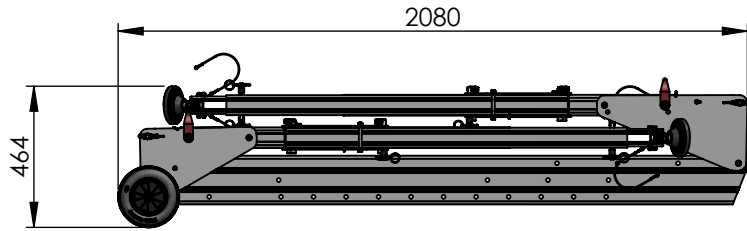

DO NOT SCALE DRAWING

REVISION 03



Reid Lifting Limited. Unit 1  
Wyeview, Newhouse Farm Ind. Est.,  
Chepstow, Monmouthshire.  
NP16 6UD, UK  
Tel +44(0) 1291 620796  
Fax +44(0) 1291 626490

[www.reidlifting.com](http://www.reidlifting.com)

[enquiries@reidlifting.com](mailto:enquiries@reidlifting.com)

	NAME	DATE	FINISH:
DRAWN	SS	05/07/2021	Anodised
CHK'D			MATERIAL:
APPV'D	AB	18/08/2023	Aluminium Alloy
<small>ALL COPYRIGHT AND DESIGN RIGHT SUBSISTING IN THIS DOCUMENT IS THE PROPERTY OF REID LIFTING LIMITED AND MAY NOT BE REPRODUCED WITHOUT REID LIFTING'S CONSENT. THIS DOCUMENT AND THE INFORMATION CONTAINED WITHIN IT IS CONFIDENTIAL AND MAY NOT BE DISCLOSED TO ANY THIRD PARTY NOR USED FOR ANY UNAUTHORISED PURPOSE WITHOUT REID LIFTING'S CONSENT</small>			
UNLESS OTHERWISE SPECIFIED:			
DIMENSIONS ARE IN MILLIMETERS			

TITLE:	DWG NO.	Scale	Sheet
Porta-Gantry Rapide Standard Frame WLL1000kg 2000mm Beam - Adjustable Feet	PGR1TS20K	1:25	A4
Estimated Weight: 52kg	SHEET 1 OF 2		

## General Specification

- Maximum rated capacity for goods lifting - 1000kg
- Maximum rated capacity for personnel lifting - 500kg
- Beam deflection at maximum rated capacity of 1000kg - 10-20 mm at centre of span
- Maximum pad surface pressure at full load - 0.52 MPa
- Assembled gantry weight (excluding trolleys) - 52kg
- All welding to BS EN ISO 15614-2: 2005 by certified welders.
- For further details and assembly information refer to Operations and Maintenance Manual for Porta Gantry Rapide Product. (available at [www.reidlifting.com](http://www.reidlifting.com))

## Fall Protection Standards

- Certified to EN795:2012 Type B & supplied under PPE Regulation 2016/425
- Notified Body Witness tested to the requirements of PD CEN/TS16415:2013 for 3 persons
- Exceeds the requirements of IRATA ICOP & BS7985 (15kN MBL)

## Materials & Finishes

- Frame and beam - 6082 T6 Aluminium alloy. Anodised.
- Castors - Steel. Bright Zinc Plated.
- Castor Wheels & Rollers - Nylon & Rubber
- Fixings - Steel. Grade 12:9. Bright Zinc Plated.

Note: Trolleys & Sheave Carrier shown in system as a reference

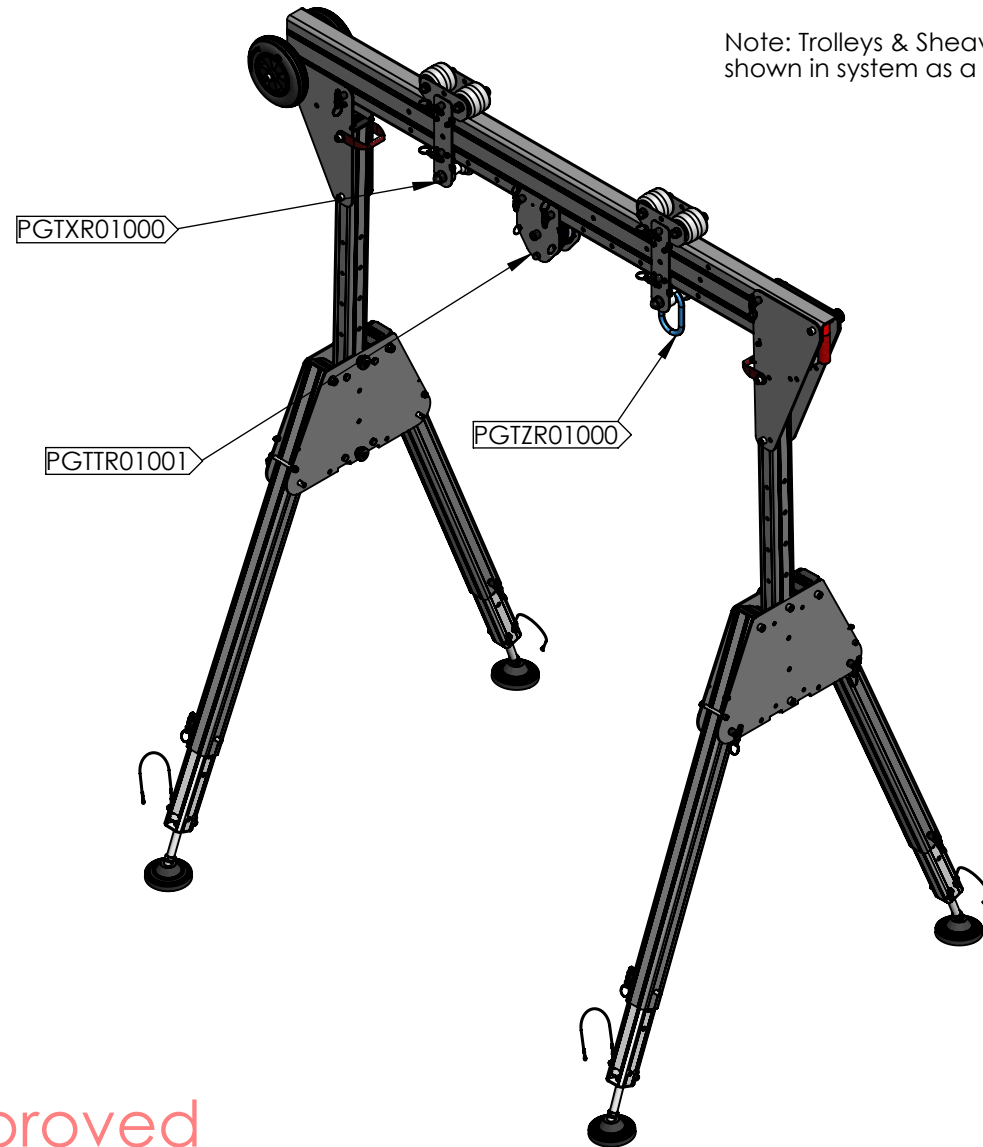

Approved

DO NOT SCALE DRAWING

REVISION 03

	NAME	DATE
DRAWN	SS	05/07/2021
CHK'D		
APP'VD	AB	18/08/2023

UNLESS OTHERWISE SPECIFIED:  
DIMENSIONS ARE IN MILLIMETERS

ALL COPYRIGHT AND DESIGN RIGHT SUBSISTING IN THIS DOCUMENT IS THE PROPERTY OF REID LIFTING LIMITED AND MAY NOT BE REPRODUCED WITHOUT REID LIFTING'S CONSENT. THIS DOCUMENT AND THE INFORMATION CONTAINED WITHIN IT IS CONFIDENTIAL AND MAY NOT BE DISCLOSED TO ANY THIRD PARTY NOR USED FOR ANY UNAUTHORISED PURPOSE WITHOUT REID LIFTING'S CONSENT



TITLE: Porta-Gantry Rapide Standard Frame WLL1000kg 2000mm Beam - Adjustable Feet

DWG NO. PGR1TS20K A4

Estimated Weight: 52kg 1:20 SHEET 2 OF 2



Reid Lifting Limited. Unit 1  
Wyeview, Newhouse Farm Ind. Est.,  
Chepstow, Monmouthshire.  
NP16 6UD, UK  
Tel +44(0)1291 620796  
Fax: +44(0)1291 626490

[www.reidlifting.com](http://www.reidlifting.com)

[enquiries@reidlifting.com](mailto:enquiries@reidlifting.com)

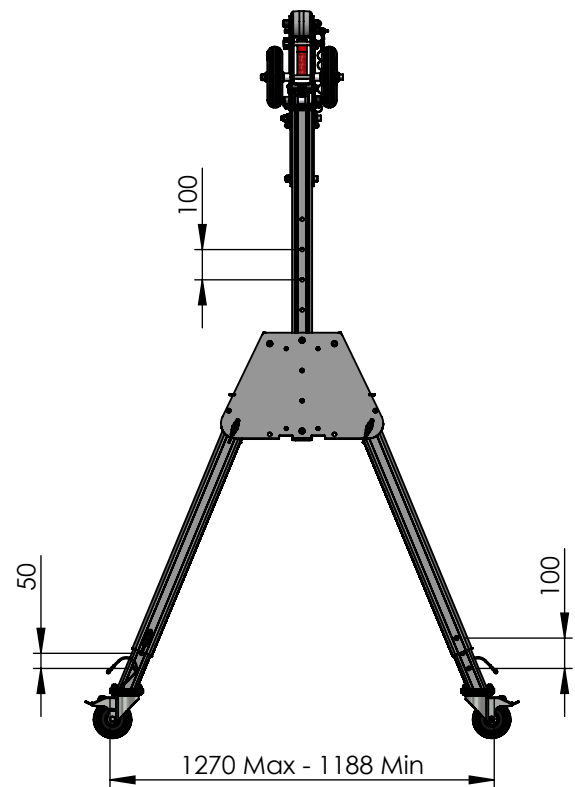
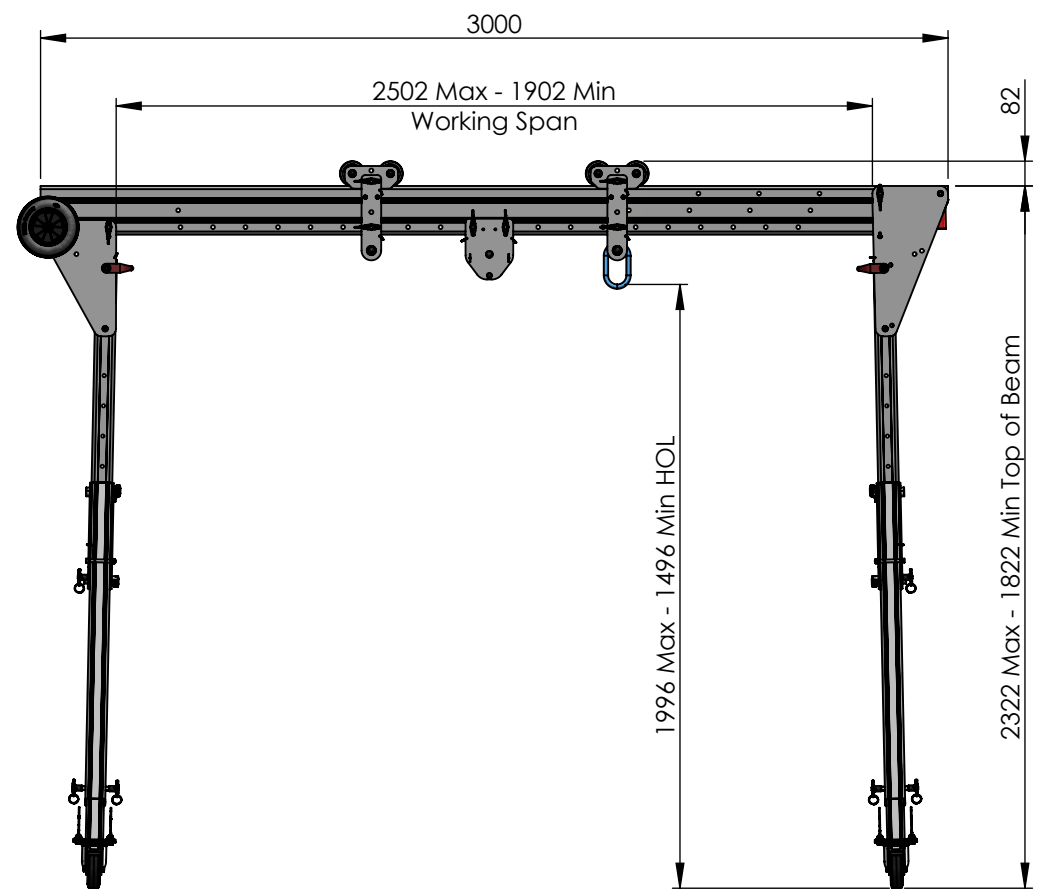
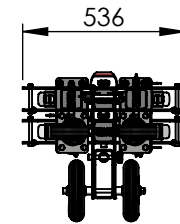
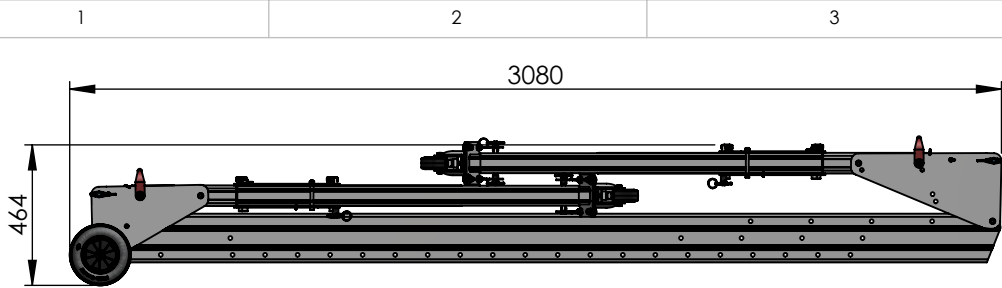

DO NOT SCALE DRAWING

REVISION 03

	NAME	DATE	FINISH:
DRAWN	SS	01/07/2021	Anodised
CHK'D			MATERIAL:
APPV'D	AB	18/08/2023	Aluminium Alloy
<small>ALL COPYRIGHT AND DESIGN RIGHT SUBSISTING IN THIS DOCUMENT IS THE PROPERTY OF REID LIFTING LIMITED AND MAY NOT BE REPRODUCED WITHOUT REID LIFTING'S CONSENT. THIS DOCUMENT AND THE INFORMATION CONTAINED WITHIN IT IS CONFIDENTIAL AND MAY NOT BE DISCLOSED TO ANY THIRD PARTY NOR USED FOR ANY UNAUTHORISED PURPOSE WITHOUT REID LIFTING'S CONSENT</small>			
UNLESS OTHERWISE SPECIFIED:			
DIMENSIONS ARE IN MILLIMETERS			

TITLE: Porta-Gantry Rapide Standard Frame WLL1000kg 3000mm Beam - Castors



Reid Lifting Limited. Unit 1  
Wyeview, Newhouse Farm Ind. Est.,  
Chepstow, Monmouthshire.  
NP16 6UD, UK  
Tel +44(0) 1291 620796  
Fax +44(0) 1291 626490

[www.reidlifting.com](http://www.reidlifting.com)

[enquiries@reidlifting.com](mailto:enquiries@reidlifting.com)



DWG NO. PGR1TS30J A4

Estimated Weight: 57kg 1:25 SHEET 1 OF 2

## General Specification

- Maximum rated capacity for goods lifting - 1000kg
- Maximum rated capacity for personnel lifting - 500kg
- Beam deflection at maximum rated capacity of 1000kg - 20-30 mm at centre of span
- Maximum castor surface pressure at full load - 16.77 MPa
- Assembled gantry weight (excluding trolleys) - 57kg
- All welding to BS EN ISO 15614-2: 2005 by certified welders.
- For further details and assembly information refer to Operations and Maintenance Manual for Porta Gantry Rapide Product. (available at [www.reidlifting.com](http://www.reidlifting.com))

## Fall Protection Standards

- Certified to EN795:2012 Type B & supplied under PPE Regulation 2016/425
- Notified Body Witness tested to the requirements of PD CEN/TS16415:2013 for 3 persons
- Exceeds the requirements of IRATA ICOP & BS7985 (15kN MBL)

## Materials & Finishes

- Frame and beam - 6082 T6 Aluminium alloy. Anodised.
- Castors - Steel. Bright Zinc Plated.
- Castor Wheels & Rollers - Nylon & Rubber
- Fixings - Steel. Grade 12:9. Bright Zinc Plated.

Note: Trolleys & Sheave Carrier shown in system as a reference



DO NOT SCALE DRAWING

REVISION 03

	NAME	DATE
DRAWN	SS	01/07/2021
CHK'D		
APP'VD	AB	18/08/2023

UNLESS OTHERWISE SPECIFIED:  
DIMENSIONS ARE IN MILLIMETERS

ALL COPYRIGHT AND DESIGN RIGHT SUBSISTING IN THIS DOCUMENT IS THE PROPERTY OF REID LIFTING LIMITED AND MAY NOT BE REPRODUCED WITHOUT REID LIFTING'S CONSENT. THIS DOCUMENT AND THE INFORMATION CONTAINED WITHIN IT IS CONFIDENTIAL AND MAY NOT BE DISCLOSED TO ANY THIRD PARTY NOR USED FOR ANY UNAUTHORISED PURPOSE WITHOUT REID LIFTING'S CONSENT



TITLE: Porta-Gantry Rapide Standard Frame WLL1000kg 3000mm Beam - Castors

DWG NO. PGR1TS30J A4

Estimated Weight: 57kg 1:25 SHEET 2 OF 2



Reid Lifting Limited. Unit 1  
Wyeview, Newhouse Farm Ind. Est.,  
Chepstow, Monmouthshire.  
NP16 6UD, UK  
Tel +44(0)1291 620796  
Fax: +44(0)1291 626490

[www.reidlifting.com](http://www.reidlifting.com)

[enquiries@reidlifting.com](mailto:enquiries@reidlifting.com)

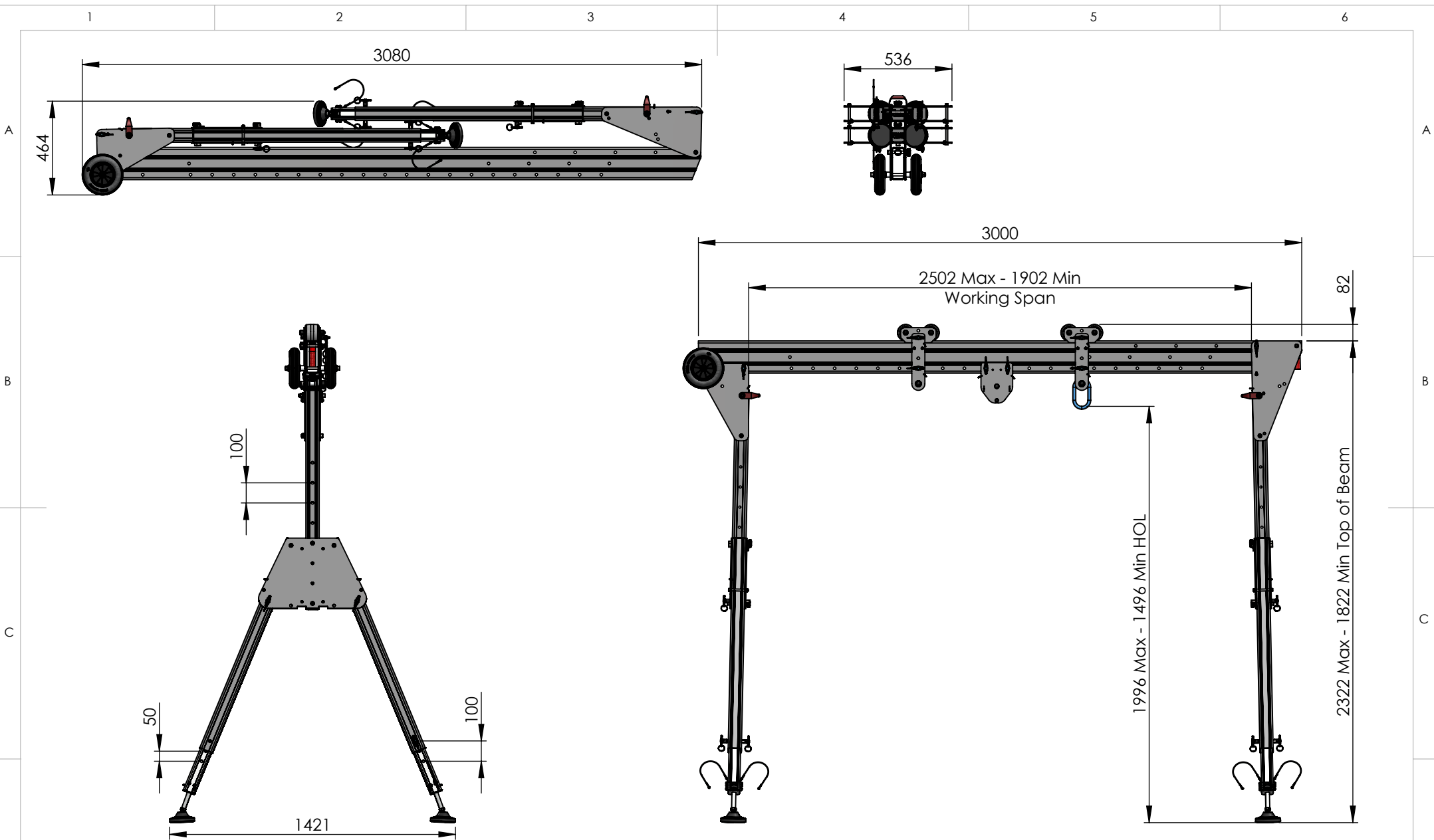

DO NOT SCALE DRAWING

REVISION 03



Reid Lifting Limited. Unit 1  
 Wyeview, Newhouse Farm Ind. Est.,  
 Chepstow, Monmouthshire.  
 NP16 6UD, UK  
 Tel +44(0) 1291 620796  
 Fax +44(0) 1291 626490

[www.reidlifting.com](http://www.reidlifting.com)

[enquiries@reidlifting.com](mailto:enquiries@reidlifting.com)

	NAME	DATE	FINISH:
DRAWN	SS	05/07/2021	Anodised
CHK'D			MATERIAL:
APPV'D	AB	18/08/2023	Aluminium Alloy
<small>ALL COPYRIGHT AND DESIGN RIGHT SUBSISTING IN THIS DOCUMENT IS THE PROPERTY OF REID LIFTING LIMITED AND MAY NOT BE REPRODUCED WITHOUT REID LIFTING'S CONSENT. THIS DOCUMENT AND THE INFORMATION CONTAINED WITHIN IT IS CONFIDENTIAL AND MAY NOT BE DISCLOSED TO ANY THIRD PARTY NOR USED FOR ANY UNAUTHORISED PURPOSE WITHOUT REID LIFTING'S CONSENT</small>			
UNLESS OTHERWISE SPECIFIED:			
DIMENSIONS ARE IN MILLIMETERS			

TITLE:	DWG NO.	Scale	SHEET
Porta-Gantry Rapide Standard Frame WLL1000kg 3000mm Beam - Adjustable Feet	PGR1TS30K	1:25	A4
Estimated Weight: 57kg			SHEET 1 OF 2



## General Specification

- Maximum rated capacity for goods lifting - 1000kg
- Maximum rated capacity for personnel lifting - 500kg
- Beam deflection at maximum rated capacity of 1000kg - 20-30 mm at centre of span
- Maximum pad surface pressure at full load - 0.53 MPa
- Assembled gantry weight (excluding trolleys) - 57kg
- All welding to BS EN ISO 15614-2: 2005 by certified welders.
- For further details and assembly information refer to Operations and Maintenance Manual for Porta Gantry Rapide Product. (available at [www.reidlifting.com](http://www.reidlifting.com))

## Fall Protection Standards

- Certified to EN795:2012 Type B & supplied under PPE Regulation 2016/425
- Notified Body Witness tested to the requirements of PD CEN/TS16415:2013 for 3 persons
- Exceeds the requirements of IRATA ICOP & BS7985 (15kN MBL)

## Materials & Finishes

- Frame and beam - 6082 T6 Aluminium alloy. Anodised.
- Castors - Steel. Bright Zinc Plated.
- Castor Wheels & Rollers - Nylon & Rubber
- Fixings - Steel. Grade 12:9. Bright Zinc Plated.

Note: Trolleys & Sheave Carrier shown in system as a reference



Approved

DO NOT SCALE DRAWING

REVISION 03

	NAME	DATE
DRAWN	SS	05/07/2021
CHK'D		
APP'VD	AB	18/08/2023

UNLESS OTHERWISE SPECIFIED:  
DIMENSIONS ARE IN MILLIMETERS

ALL COPYRIGHT AND DESIGN RIGHT SUBSISTING IN THIS DOCUMENT IS THE PROPERTY OF REID LIFTING LIMITED AND MAY NOT BE REPRODUCED WITHOUT REID LIFTING'S CONSENT. THIS DOCUMENT AND THE INFORMATION CONTAINED WITHIN IT IS CONFIDENTIAL AND MAY NOT BE DISCLOSED TO ANY THIRD PARTY NOR USED FOR ANY UNAUTHORISED PURPOSE WITHOUT REID LIFTING'S CONSENT



TITLE: Porta-Gantry Rapide Standard Frame WLL1000kg 3000mm Beam - Adjustable Feet

DWG NO. PGR1TS30K A4

Estimated Weight: 57kg 1:25 SHEET 2 OF 2



Reid Lifting Limited. Unit 1  
Wyeview, Newhouse Farm Ind. Est.,  
Chepstow, Monmouthshire.  
NP16 6UD, UK  
Tel +44(0)1291 620796  
Fax: +44(0)1291 626490

[www.reidlifting.com](http://www.reidlifting.com)

[enquiries@reidlifting.com](mailto:enquiries@reidlifting.com)

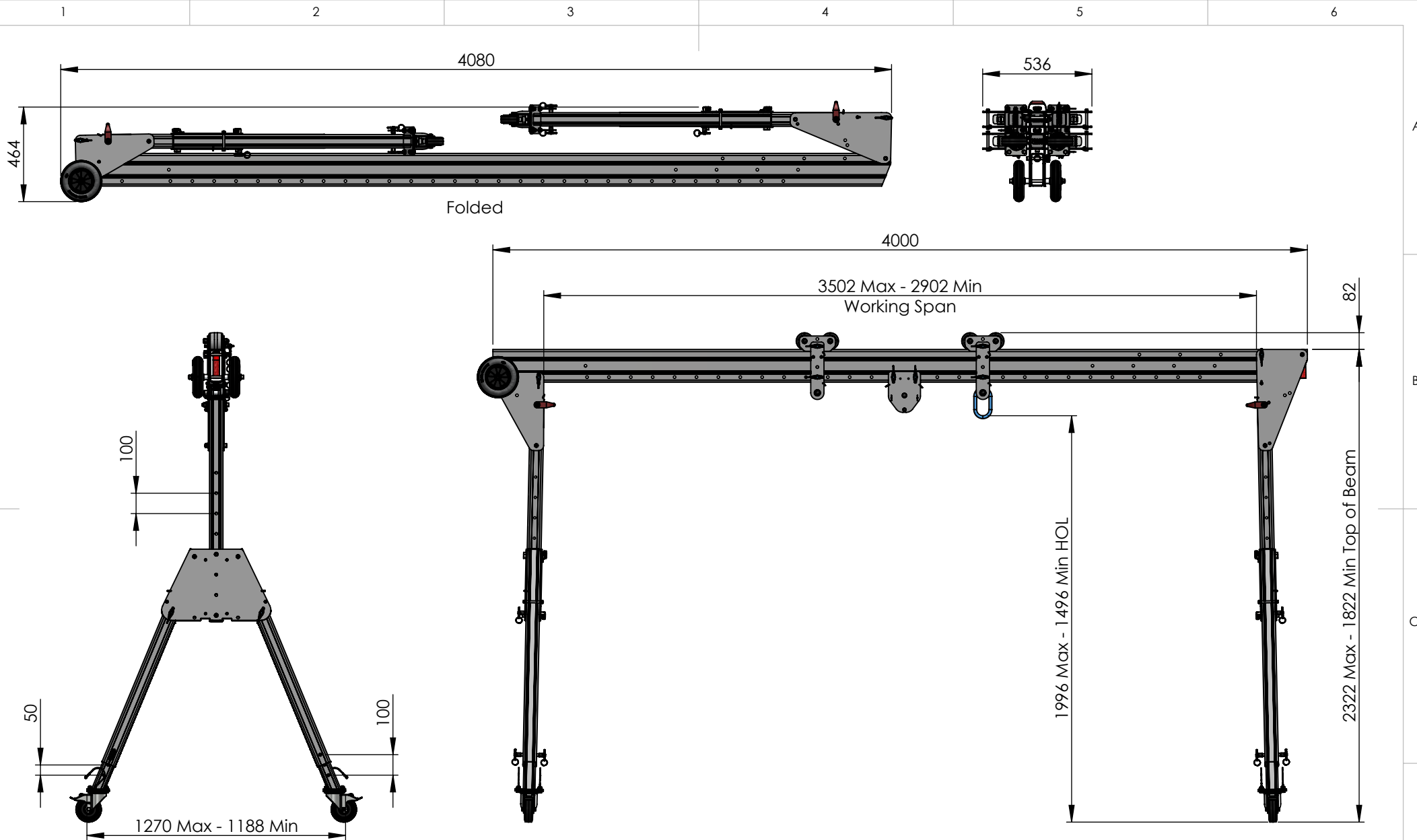

DO NOT SCALE DRAWING

REVISION 03



Reid Lifting Limited. Unit 1  
 Wyeview, Newhouse Farm Ind. Est.,  
 Chepstow, Monmouthshire.  
 NP16 6UD, UK  
 Tel +44(0) 1291 620796  
 Fax +44(0) 1291 626490

[www.reidlifting.com](http://www.reidlifting.com)

[enquiries@reidlifting.com](mailto:enquiries@reidlifting.com)

	NAME	DATE	FINISH:
DRAWN	SS	01/07/2021	Anodised
CHK'D			MATERIAL:
APPV'D	AB	18/08/2023	Aluminium Alloy
ALL COPYRIGHT AND DESIGN RIGHT SUBSISTING IN THIS DOCUMENT IS THE PROPERTY OF REID LIFTING LIMITED AND MAY NOT BE REPRODUCED WITHOUT REID LIFTING'S CONSENT. THIS DOCUMENT AND THE INFORMATION CONTAINED WITHIN IT IS CONFIDENTIAL AND MAY NOT BE DISCLOSED TO ANY THIRD PARTY NOR USED FOR ANY UNAUTHORISED PURPOSE WITHOUT REID LIFTING'S CONSENT			
UNLESS OTHERWISE SPECIFIED:			
DIMENSIONS ARE IN MILLIMETERS			

TITLE: Porta-Gantry Rapide Standard  
 Frame WLL1000kg 4000mm  
 Beam - Castors

DWG NO. PGR1TS40J A4

Estimated Weight: 61kg 1:25 SHEET 1 OF 2

## General Specification

- Maximum rated capacity for goods lifting - 1000kg
- Maximum rated capacity for personnel lifting - 500kg
- Beam deflection at maximum rated capacity of 1000kg - 30-45 mm at centre of span
- Maximum castor surface pressure at full load - 16.83 MPa
- Assembled gantry weight (excluding trolleys) - 61kg
- All welding to BS EN ISO 15614-2: 2005 by certified welders.
- For further details and assembly information refer to Operations and Maintenance Manual for Porta Gantry Rapide Product. (available at [www.reidlifting.com](http://www.reidlifting.com))

Note: Trolleys & Sheave Carrier shown in system as a reference



## Fall Protection Standards

- Certified to EN795:2012 Type B & supplied under PPE Regulation 2016/425
- Notified Body Witness tested to the requirements of PD CEN/TS16415:2013 for 3 persons
- Exceeds the requirements of IRATA ICOP & BS7985 (15kN MBL)

## Materials & Finishes

- Frame and beam - 6082 T6 Aluminium alloy. Anodised.
- Castors - Steel. Bright Zinc Plated.
- Castor Wheels & Rollers - Nylon & Rubber
- Fixings - Steel. Grade 12:9. Bright Zinc Plated.

DO NOT SCALE DRAWING

REVISION 03

	NAME	DATE
DRAWN	SS	01/07/2021
CHK'D		
APP'VD	AB	18/08/2023

UNLESS OTHERWISE SPECIFIED:  
DIMENSIONS ARE IN MILLIMETERS

ALL COPYRIGHT AND DESIGN RIGHT SUBSISTING IN THIS DOCUMENT IS THE PROPERTY OF REID LIFTING LIMITED AND MAY NOT BE REPRODUCED WITHOUT REID LIFTING'S CONSENT. THIS DOCUMENT AND THE INFORMATION CONTAINED WITHIN IT IS CONFIDENTIAL AND MAY NOT BE DISCLOSED TO ANY THIRD PARTY NOR USED FOR ANY UNAUTHORISED PURPOSE WITHOUT REID LIFTING'S CONSENT



TITLE: Porta-Gantry Rapide Standard Frame WLL1000kg 4000mm Beam - Castors

DWG NO. PGR1TS40J A4

Estimated Weight: 61kg 1:30 SHEET 2 OF 2



Reid Lifting Limited. Unit 1  
Wyeview, Newhouse Farm Ind. Est.,  
Chepstow, Monmouthshire.  
NP16 6UD, UK  
Tel +44(0)1291 620796  
Fax: +44(0)1291 626490

[www.reidlifting.com](http://www.reidlifting.com)

[enquiries@reidlifting.com](mailto:enquiries@reidlifting.com)

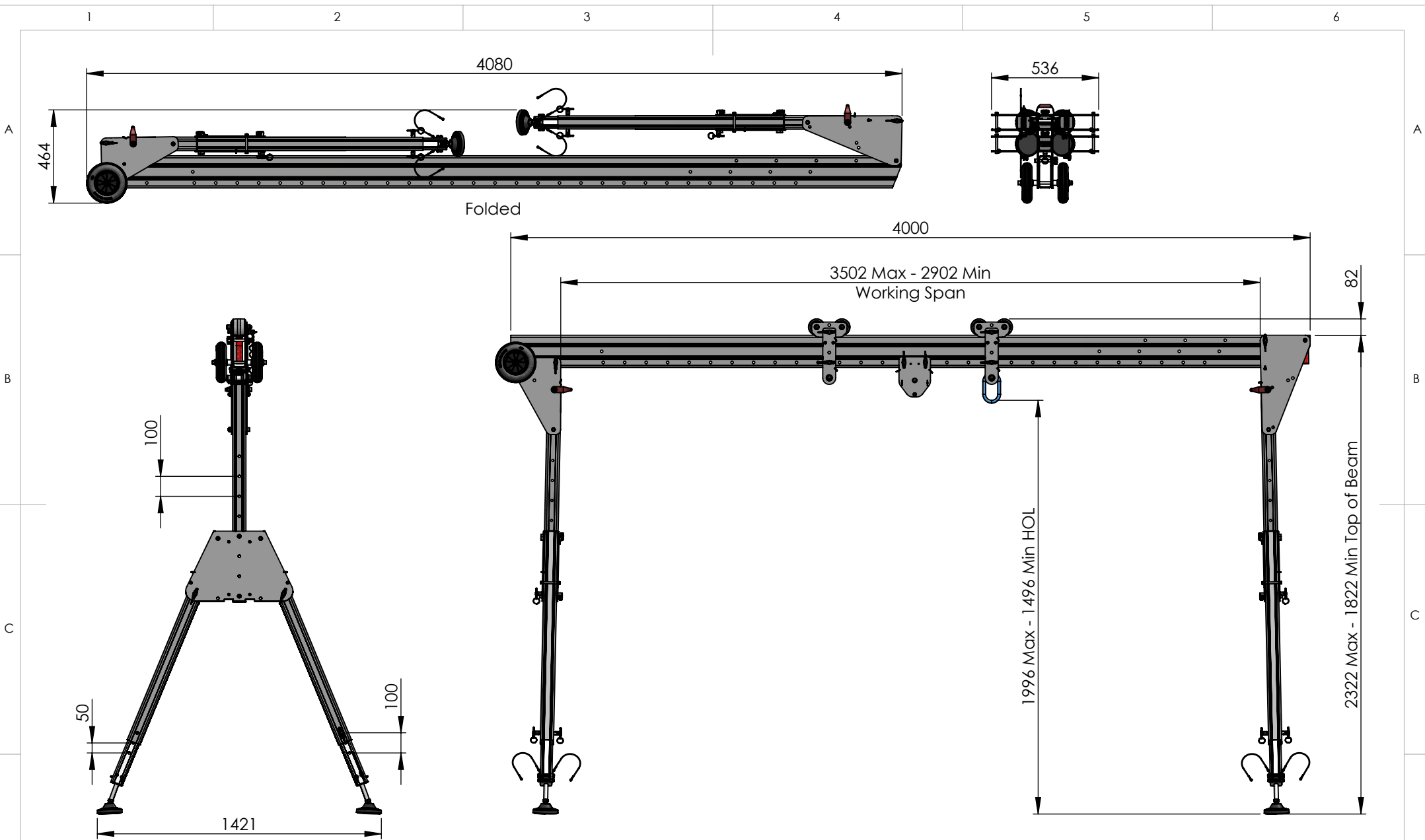

DO NOT SCALE DRAWING

REVISION 03

	NAME	DATE	FINISH:
DRAWN	SS	05/07/2021	Anodised
CHK'D			MATERIAL:
APPV'D	AB	18/08/2023	Aluminium Alloy
UNLESS OTHERWISE SPECIFIED: DIMENSIONS ARE IN MILLIMETERS			

TITLE: Porta-Gantry Rapide Standard Frame WLL1000kg 4000mm Beam - Adjustable Feet



Reid Lifting Limited. Unit 1  
Wyeview, Newhouse Farm Ind. Est.,  
Chepstow, Monmouthshire.  
NP16 6UD, UK  
Tel +44(0) 1291 620796  
Fax +44(0) 1291 626490

[www.reidlifting.com](http://www.reidlifting.com)

[enquiries@reidlifting.com](mailto:enquiries@reidlifting.com)

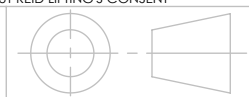

DWG NO. PGR1TS40K A4

Estimated Weight: 61kg 1:25 SHEET 1 OF 2

## General Specification

- Maximum rated capacity for goods lifting - 1000kg
- Maximum rated capacity for personnel lifting - 500kg
- Beam deflection at maximum rated capacity of 1000kg - 30-45 mm at centre of span
- Maximum pad surface pressure at full load - 0.53 MPa
- Assembled gantry weight (excluding trolleys) - 61kg
- All welding to BS EN ISO 15614-2: 2005 by certified welders.
- For further details and assembly information refer to Operations and Maintenance Manual for Porta Gantry Rapide Product. (available at [www.reidlifting.com](http://www.reidlifting.com))

Note: Trolleys & Sheave Carrier shown in system as a reference



## Fall Protection Standards

- Certified to EN795:2012 Type B & supplied under PPE Regulation 2016/425
- Notified Body Witness tested to the requirements of PD CEN/TS16415:2013 for 3 persons
- Exceeds the requirements of IRATA ICOP & BS7985 (15kN MBL)

## Materials & Finishes

- Frame and beam - 6082 T6 Aluminium alloy. Anodised.
- Castors - Steel. Bright Zinc Plated.
- Castor Wheels & Rollers - Nylon & Rubber
- Fixings - Steel. Grade 12:9. Bright Zinc Plated.

Approved

DO NOT SCALE DRAWING

REVISION 03

	NAME	DATE
DRAWN	SS	05/07/2021
CHK'D		
APP'VD	AB	18/08/2023

UNLESS OTHERWISE SPECIFIED:  
DIMENSIONS ARE IN MILLIMETERS

ALL COPYRIGHT AND DESIGN RIGHT SUBSISTING IN THIS DOCUMENT IS THE PROPERTY OF REID LIFTING LIMITED AND MAY NOT BE REPRODUCED WITHOUT REID LIFTING'S CONSENT. THIS DOCUMENT AND THE INFORMATION CONTAINED WITHIN IT IS CONFIDENTIAL AND MAY NOT BE DISCLOSED TO ANY THIRD PARTY NOR USED FOR ANY UNAUTHORISED PURPOSE WITHOUT REID LIFTING'S CONSENT



TITLE: Porta-Gantry Rapide Standard Frame WLL1000kg 4000mm Beam - Adjustable Feet

DWG NO. PGR1TS40K A4

Estimated Weight: 61kg 1:30 SHEET 2 OF 2



Reid Lifting Limited. Unit 1  
Wyeview, Newhouse Farm Ind. Est.,  
Chepstow, Monmouthshire.  
NP16 6UD, UK  
Tel +44(0)1291 620796  
Fax: +44(0)1291 626490

[www.reidlifting.com](http://www.reidlifting.com)

[enquiries@reidlifting.com](mailto:enquiries@reidlifting.com)

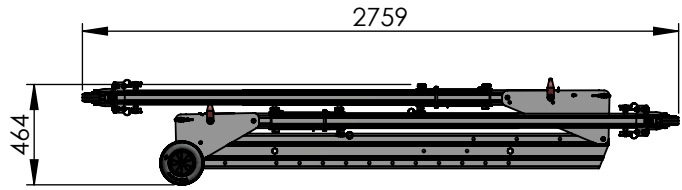

Folded

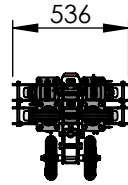

A

A

B

B

C

C

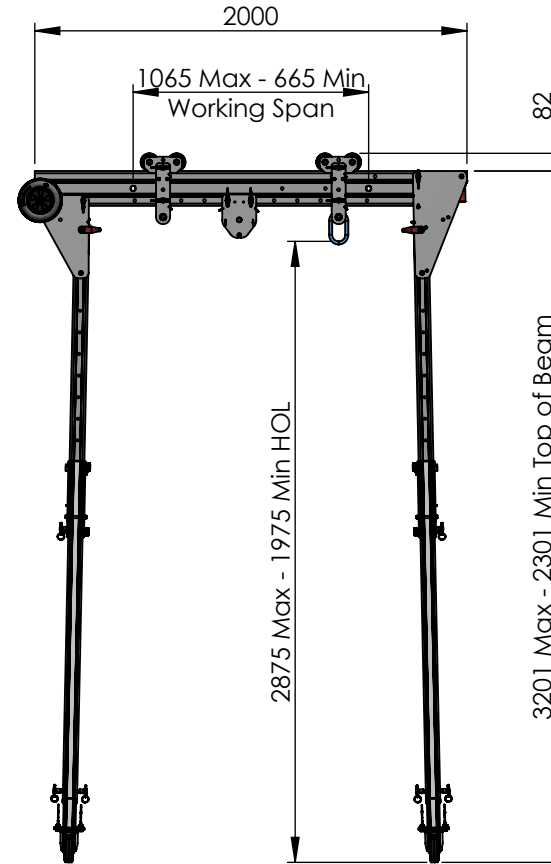
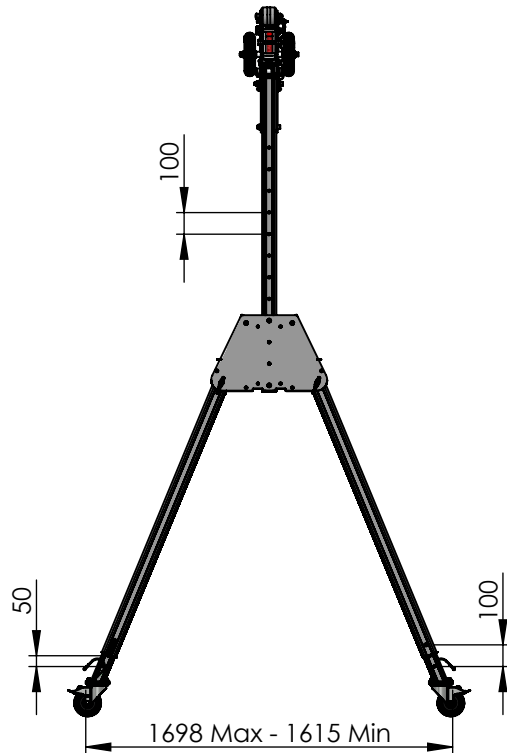

DO NOT SCALE DRAWING

REVISION

**03**



Reid Lifting Limited. Unit 1  
Wyeview, Newhouse Farm Ind. Est.,  
Chepstow, Monmouthshire.  
NP16 6UD, UK  
Tel +44(0) 1291 620796  
Fax +44(0) 1291 626490

[www.reidlifting.com](http://www.reidlifting.com)

[enquiries@reidlifting.com](mailto:enquiries@reidlifting.com)

	NAME	DATE	FINISH:
DRAWN	SS	01/07/2021	Anodised
CHK'D			MATERIAL:
APPV'D	CM	15/11/2022	Aluminium Alloy
<small>ALL COPYRIGHT AND DESIGN RIGHT SUBSISTING IN THIS DOCUMENT IS THE PROPERTY OF REID LIFTING LIMITED AND MAY NOT BE REPRODUCED WITHOUT REID LIFTING'S CONSENT. THIS DOCUMENT AND THE INFORMATION CONTAINED WITHIN IT IS CONFIDENTIAL AND MAY NOT BE DISCLOSED TO ANY THIRD PARTY NOR USED FOR ANY UNAUTHORISED PURPOSE WITHOUT REID LIFTING'S CONSENT</small>			
UNLESS OTHERWISE SPECIFIED:			
DIMENSIONS ARE IN MILLIMETERS			

TITLE:	<b>Porta-Gantry Rapide Tall Frame WLL1000kg 2000mm Beam - Castors</b>	
DWG NO.	<b>PGR1TT20J</b>	A4
Estimated Weight:	60kg	1:35
		SHEET 1 OF 2

1

2

3

4

5

6

## General Specification

- Maximum rated capacity for goods lifting - 1000kg
- Maximum rated capacity for personnel lifting - 500kg
- Beam deflection at maximum rated capacity of 1000kg - 15-25 mm at centre of span
- Maximum castor surface pressure at full load - 16.81 MPa
- Assembled gantry weight (excluding trolleys) - 60kg
- All welding to BS EN ISO 15614-2: 2005 by certified welders.
- For further details and assembly information refer to Operations and Maintenance Manual for Porta Gantry Rapide Product. (available at [www.reidlifting.com](http://www.reidlifting.com))

## Fall Protection Standards

- Certified to EN795:2012 Type B & supplied under PPE Regulation 2016/425
- Notified Body Witness tested to the requirements of PD CEN/TS16415:2013 for 3 persons
- Exceeds the requirements of IRATA ICOP & BS7985 (15kN MBL)

## Materials & Finishes

- Frame and beam - 6082 T6 Aluminium alloy. Anodised.
- Castors - Steel. Bright Zinc Plated.
- Castor Wheels & Rollers - Nylon & Rubber
- Fixings - Steel. Grade 12:9. Bright Zinc Plated.

Note: Trolleys & Sheave Carrier shown in system as a reference



DO NOT SCALE DRAWING

REVISION

**03**



Reid Lifting Limited. Unit 1  
Wyeview, Newhouse Farm Ind. Est.,  
Chepstow, Monmouthshire.  
NP16 6UD, UK

Tel +44(0)1291 620796  
Fax: +44(0)1291 626490

[www.reidlifting.com](http://www.reidlifting.com)

[enquiries@reidlifting.com](mailto:enquiries@reidlifting.com)

	NAME	DATE
DRAWN	SS	01/07/2021
CHK'D		
APP'VD	CM	15/11/2022

UNLESS OTHERWISE SPECIFIED:  
DIMENSIONS ARE IN MILLIMETERS

ALL COPYRIGHT AND DESIGN RIGHT SUBSISTING IN THIS DOCUMENT IS THE PROPERTY OF REID LIFTING LIMITED AND MAY NOT BE REPRODUCED WITHOUT REID LIFTING'S CONSENT. THIS DOCUMENT AND THE INFORMATION CONTAINED WITHIN IT IS CONFIDENTIAL AND MAY NOT BE DISCLOSED TO ANY THIRD PARTY NOR USED FOR ANY UNAUTHORISED PURPOSE WITHOUT REID LIFTING'S CONSENT



TITLE: **Porta-Gantry Rapide Tall  
Frame WLL1000kg 2000mm  
Beam - Castors**

DWG NO.

**PGR1TT20J**

A4

Estimated Weight: 60kg

1:30

SHEET 2 OF 2

1 2 3 4 5 6

A

B

C

D

A

B

C

D

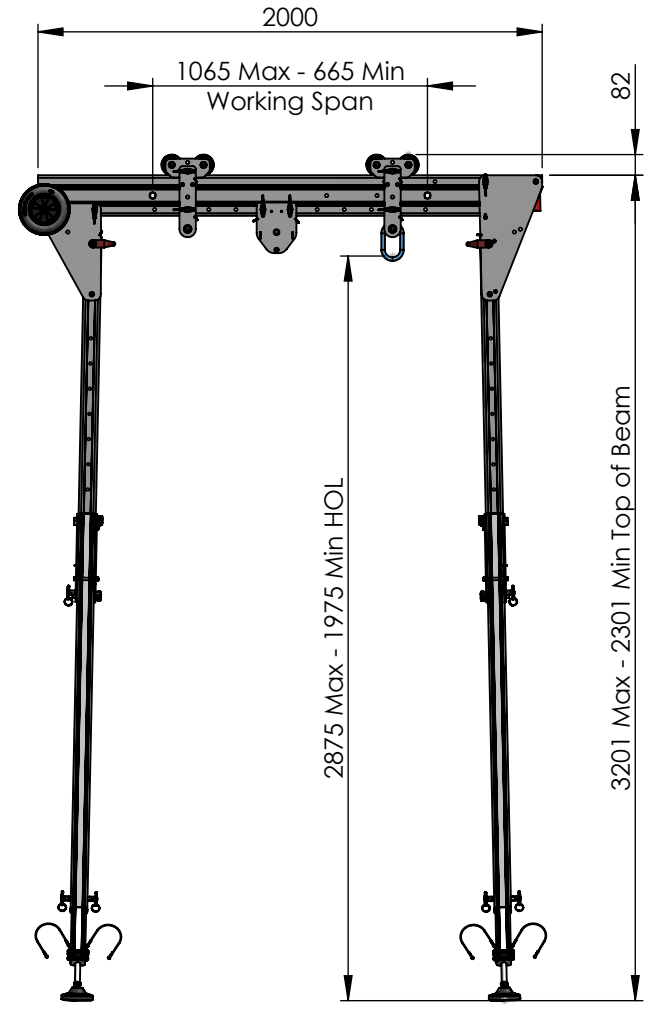
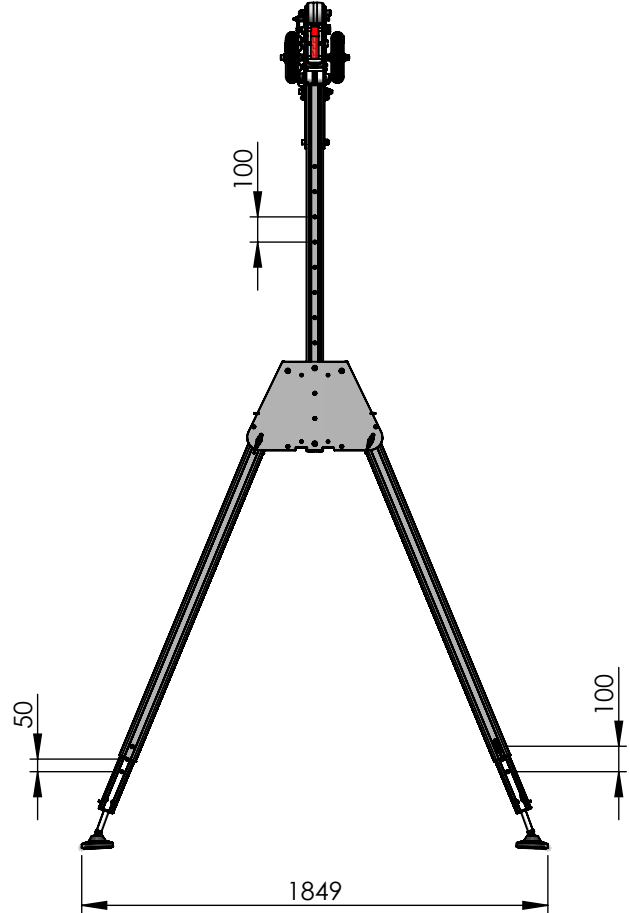
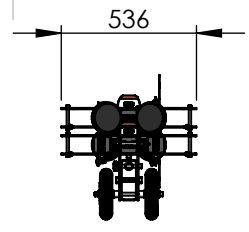
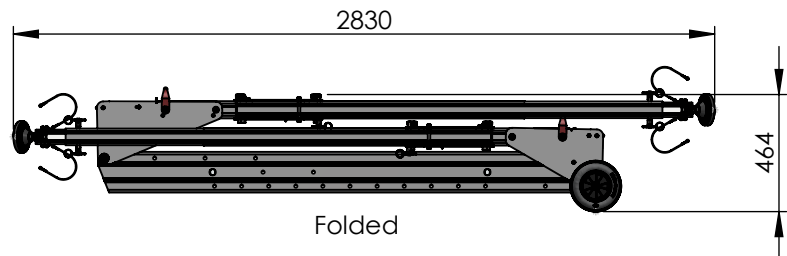

DO NOT SCALE DRAWING

REVISION **03**



Reid Lifting Limited, Unit 1, Wyeview, Newhouse Farm, Ind Est, Chepstow, Monmouth, NP16 6UD, UK

Tel +44(0) 1291 620796  
 Fax +44(0) 1291 626490

[enquiries@reidlifting.com](mailto:enquiries@reidlifting.com)

	NAME	DATE	FINISH:
DRAWN	BJ	14/04/2020	Anodised
CHK'D	-	-	MATERIAL:
APPV'D	CM	15/11/2022	Aluminium Alloy
<small>ALL COPYRIGHT AND DESIGN RIGHT SUBSISTING IN THIS DOCUMENT IS THE PROPERTY OF REID LIFTING LIMITED AND MAY NOT BE REPRODUCED WITHOUT REID LIFTING'S CONSENT. THIS DOCUMENT AND THE INFORMATION CONTAINED WITHIN IT IS CONFIDENTIAL AND MAY NOT BE DISCLOSED TO ANY THIRD PARTY NOR USED FOR ANY UNAUTHORISED PURPOSE WITHOUT REID LIFTING'S CONSENT</small>			
UNLESS OTHERWISE SPECIFIED:			
DIMENSIONS ARE IN MILLIMETERS			

TITLE: **PORTA-Gantry Rapide Tall Frame WLL1000kg 2000mm Beam - Adjustable Feet**

DWG NO.	<b>PGR1TT20K</b>	A4
Estimated Weight:	60 kg	1:30
		SHEET 1 OF 2

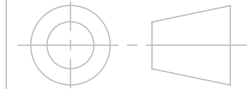

## General Specification

- Maximum rated capacity for goods lifting - 1000kg
- Maximum rated capacity for personnel lifting - 500kg
- Beam deflection at maximum rated capacity of 1000kg - 15-25 mm at centre of span
- Maximum pad surface pressure at full load - 0.53 MPa
- Assembled gantry weight (excluding trollies) - 60kg
- All welding to BS EN ISO 15614-2: 2005 by certified welders.
- For further details and assembly information refer to Operations and Maintenance Manual for Porta Gantry Product. (available at [www.reidlifting.com](http://www.reidlifting.com))

## Fall Protection Standards

- Certified to EN795:2012 Type B & supplied under PPE Regulation 2016/425
- Notified Body Witness tested to the requirements of PD CEN/TS16415:2013 for 3 persons
- Exceeds the requirements of IRATA ICOP & BS7985 (15kN MBL)
- Tested to and meets the requirements of ANSI Z359.18.2017 for 2 persons.

## Materials & Finishes

- Frame and beam - 6082 T6 Aluminium alloy. Anodised.
- Castors - Steel. Bright Zinc Plated.
- Castor Wheels & Rollers - Nylon & Polyurethane
- Fixings - Steel. Grade 12.9. Bright Zinc Plated.

Note: Trolleys & Sheave Carrier shown in system as a reference



Approved

DO NOT SCALE DRAWING

REVISION **03**

	NAME	DATE
DRAWN	BJ	14/04/2020
CHK'D		
APPV'D	CM	15/11/2022

UNLESS OTHERWISE SPECIFIED:  
DIMENSIONS ARE IN MILLIMETERS

ALL COPYRIGHT AND DESIGN RIGHT SUBSISTING IN THIS DOCUMENT IS THE PROPERTY OF REID LIFTING LIMITED AND MAY NOT BE REPRODUCED WITHOUT REID LIFTING'S CONSENT. THIS DOCUMENT AND THE INFORMATION CONTAINED WITHIN IT IS CONFIDENTIAL AND MAY NOT BE DISCLOSED TO ANY THIRD PARTY NOR USED FOR ANY UNAUTHORISED PURPOSE WITHOUT REID LIFTING'S CONSENT



TITLE: **PORTA-Gantry Rapide Tall Frame  
WLL1000kg 2000mm Beam -  
Adjustable Feet**

DWG NO.

**PGR1TT20K**

A4

Estimated Weight:

60 kg

1:30

SHEET 2 OF 2



Reid Lifting Limited. Unit 1  
Wyeview, Newhouse Farm Ind. Est.,  
Chepstow, Monmouthshire.  
NP16 6UD, UK

Tel +44(0)1291 620796  
Fax: +44(0)1291 626490

[www.reidlifting.com](http://www.reidlifting.com)

[enquiries@reidlifting.com](mailto:enquiries@reidlifting.com)

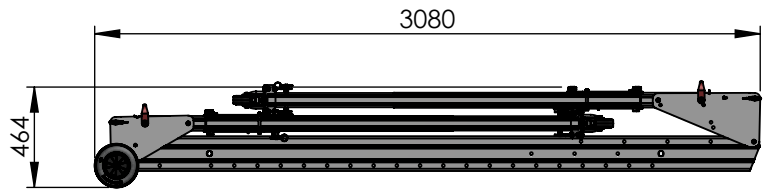

Folded

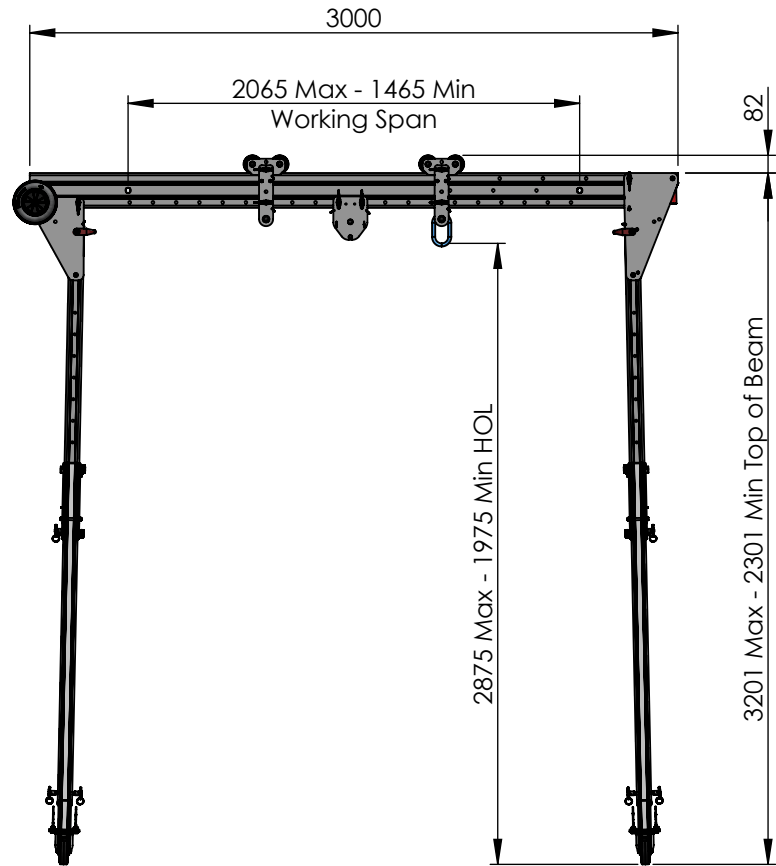
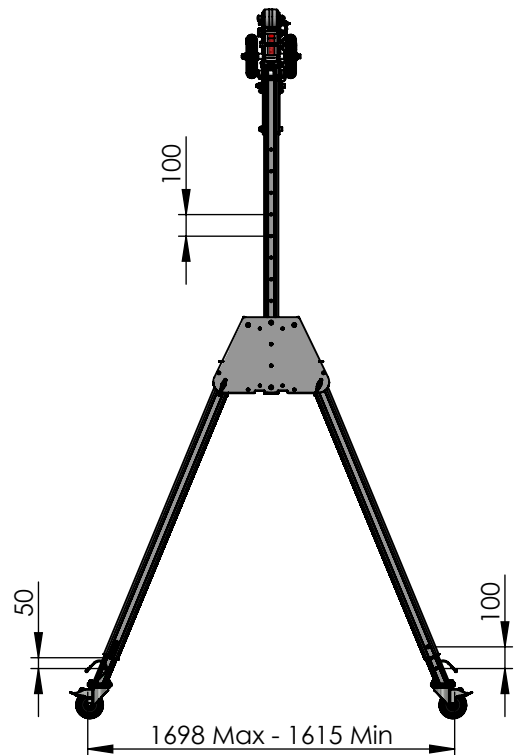
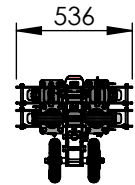

DO NOT SCALE DRAWING

REVISION **03**



Reid Lifting Limited. Unit 1  
Wyeview, Newhouse Farm Ind. Est.,  
Chepstow, Monmouthshire.  
NP16 6UD, UK  
Tel +44(0) 1291 620796  
Fax +44(0) 1291 626490

[www.reidlifting.com](http://www.reidlifting.com)

[enquiries@reidlifting.com](mailto:enquiries@reidlifting.com)

	NAME	DATE	FINISH:
DRAWN	SS	01/07/2021	Anodised
CHK'D			MATERIAL:
APPV'D	CM	15/11/2022	Aluminium Alloy
<small>ALL COPYRIGHT AND DESIGN RIGHT SUBSISTING IN THIS DOCUMENT IS THE PROPERTY OF REID LIFTING LIMITED AND MAY NOT BE REPRODUCED WITHOUT REID LIFTING'S CONSENT. THIS DOCUMENT AND THE INFORMATION CONTAINED WITHIN IT IS CONFIDENTIAL AND MAY NOT BE DISCLOSED TO ANY THIRD PARTY NOR USED FOR ANY UNAUTHORISED PURPOSE WITHOUT REID LIFTING'S CONSENT</small>			
UNLESS OTHERWISE SPECIFIED:			
DIMENSIONS ARE IN MILLIMETERS			

TITLE:	<b>Porta-Gantry Rapide Tall Frame WLL1000kg 3000mm Beam - Castors</b>	
DWG NO.	<b>PGR1TT30J</b>	A4
Estimated Weight:	64kg	1:35
		SHEET 1 OF 2



## General Specification

- Maximum rated capacity for goods lifting - 1000kg
- Maximum rated capacity for personnel lifting - 500kg
- Beam deflection at maximum rated capacity of 1000kg - 25-35 mm at centre of span
- Maximum castor surface pressure at full load - 16.88 MPa
- Assembled gantry weight (excluding trolleys) - 64kg
- All welding to BS EN ISO 15614-2: 2005 by certified welders.
- For further details and assembly information refer to Operations and Maintenance Manual for Porta Gantry Rapide Product. (available at [www.reidlifting.com](http://www.reidlifting.com))

## Fall Protection Standards

- Certified to EN795:2012 Type B & supplied under PPE Regulation 2016/425
- Notified Body Witness tested to the requirements of PD CEN/TS16415:2013 for 3 persons
- Exceeds the requirements of IRATA ICOP & BS7985 (15kN MBL)

## Materials & Finishes

- Frame and beam - 6082 T6 Aluminium alloy. Anodised.
- Castors - Steel. Bright Zinc Plated.
- Castor Wheels & Rollers - Nylon & Rubber
- Fixings - Steel. Grade 12:9. Bright Zinc Plated.

Note: Trolleys & Sheave Carrier shown in system as a reference



DO NOT SCALE DRAWING

REVISION

**03**



Reid Lifting Limited. Unit 1  
Wyeview, Newhouse Farm Ind. Est.,  
Chepstow, Monmouthshire.  
NP16 6UD, UK

Tel +44(0)1291 620796  
Fax: +44(0)1291 626490

[www.reidlifting.com](http://www.reidlifting.com)

[enquiries@reidlifting.com](mailto:enquiries@reidlifting.com)

	NAME	DATE
DRAWN	SS	01/07/2021
CHK'D		
APP'VD	CM	15/11/2022

UNLESS OTHERWISE SPECIFIED:  
DIMENSIONS ARE IN MILLIMETERS

ALL COPYRIGHT AND DESIGN RIGHT SUBSISTING IN THIS DOCUMENT IS THE PROPERTY OF REID LIFTING LIMITED AND MAY NOT BE REPRODUCED WITHOUT REID LIFTING'S CONSENT. THIS DOCUMENT AND THE INFORMATION CONTAINED WITHIN IT IS CONFIDENTIAL AND MAY NOT BE DISCLOSED TO ANY THIRD PARTY NOR USED FOR ANY UNAUTHORISED PURPOSE WITHOUT REID LIFTING'S CONSENT



TITLE: **Porta-Gantry Rapide Tall  
Frame WLL1000kg 3000mm  
Beam - Castors**

DWG NO.

**PGR1TT30J**

**A4**

Estimated Weight: 64kg

1:30

SHEET 2 OF 2

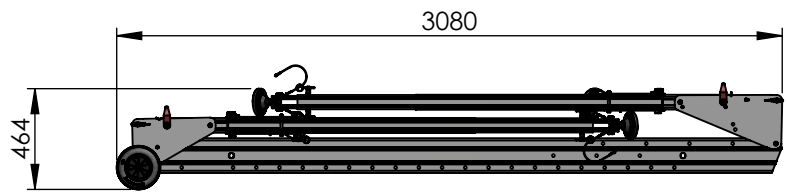

Folded

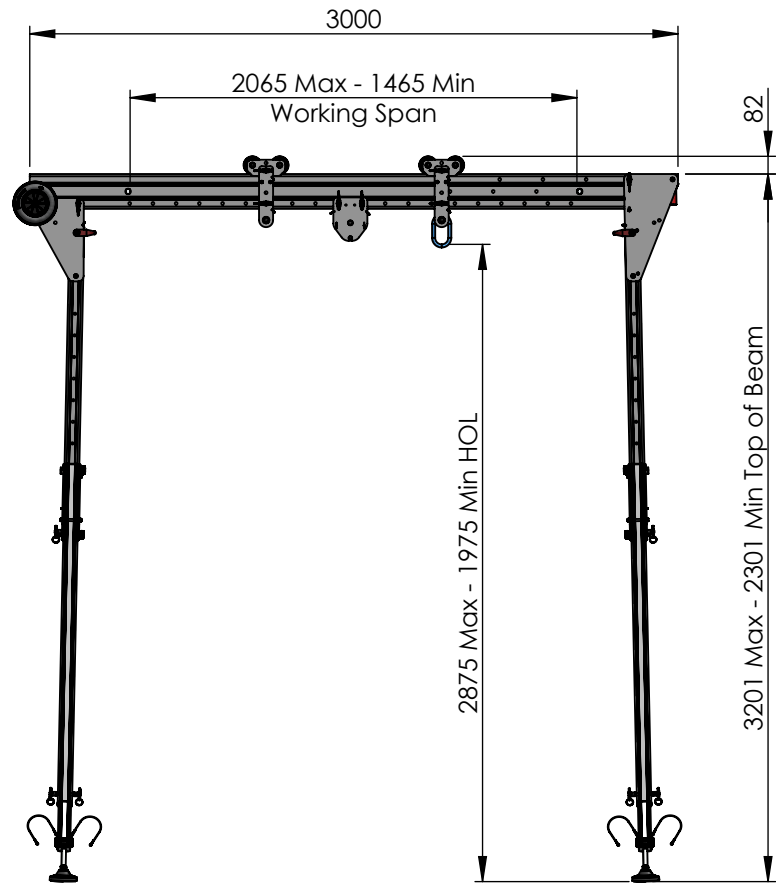
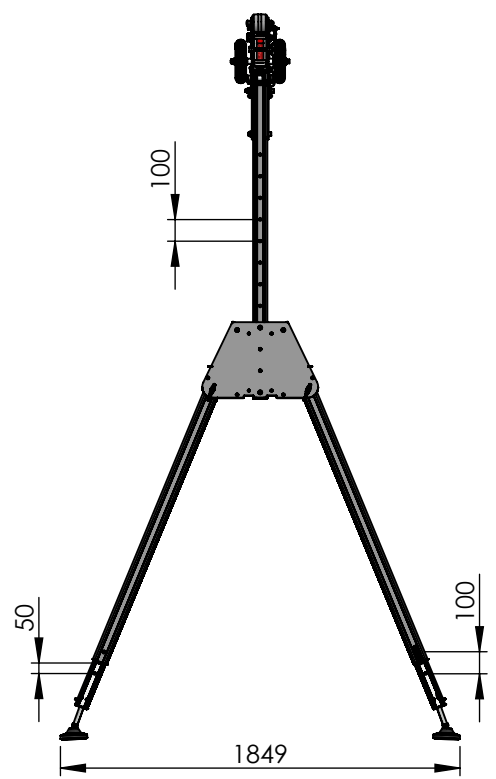
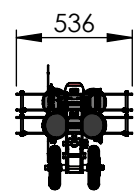

DO NOT SCALE DRAWING

REVISION **02**



Reid Lifting Limited. Unit 1  
Wyeview, Newhouse Farm Ind. Est.,  
Chepstow, Monmouthshire.  
NP16 6UD, UK  
Tel +44(0) 1291 620796  
Fax +44(0) 1291 626490  
[www.reidlifting.com](http://www.reidlifting.com)  
[enquiries@reidlifting.com](mailto:enquiries@reidlifting.com)

	NAME	DATE	FINISH:
DRAWN	SS	05/07/2021	Anodised
CHK'D			MATERIAL:
APPV'D	CM	15/11/2022	Aluminium Alloy
<small>ALL COPYRIGHT AND DESIGN RIGHT SUBSISTING IN THIS DOCUMENT IS THE PROPERTY OF REID LIFTING LIMITED AND MAY NOT BE REPRODUCED WITHOUT REID LIFTING'S CONSENT. THIS DOCUMENT AND THE INFORMATION CONTAINED WITHIN IT IS CONFIDENTIAL AND MAY NOT BE DISCLOSED TO ANY THIRD PARTY NOR USED FOR ANY UNAUTHORISED PURPOSE WITHOUT REID LIFTING'S CONSENT</small>			
UNLESS OTHERWISE SPECIFIED:			
DIMENSIONS ARE IN MILLIMETERS			

TITLE: **Porta-Gantry Rapide Tall Frame WLL1000kg 3000mm Beam - Adjustable Feet**

DWG NO.	<b>PGR1TT30K</b>	A4
Estimated Weight:	64kg	1:35
		SHEET 1 OF 2



## General Specification

- Maximum rated capacity for goods lifting - 1000kg
- Maximum rated capacity for personnel lifting - 500kg
- Beam deflection at maximum rated capacity of 1000kg - 25-35 mm at centre of span
- Maximum pad surface pressure at full load - 0.53 MPa
- Assembled gantry weight (excluding trolleys) - 64kg
- All welding to BS EN ISO 15614-2: 2005 by certified welders.
- For further details and assembly information refer to Operations and Maintenance Manual for Porta Gantry Rapide Product. (available at [www.reidlifting.com](http://www.reidlifting.com))

## Fall Protection Standards

- Certified to EN795:2012 Type B & supplied under PPE Regulation 2016/425
- Notified Body Witness tested to the requirements of PD CEN/TS16415:2013 for 3 persons
- Exceeds the requirements of IRATA ICOP & BS7985 (15kN MBL)

## Materials & Finishes

- Frame and beam - 6082 T6 Aluminium alloy. Anodised.
- Castors - Steel. Bright Zinc Plated.
- Castor Wheels & Rollers - Nylon & Rubber
- Fixings - Steel. Grade 12:9. Bright Zinc Plated.

Note: Trolleys & Sheave Carrier shown in system as a reference



DO NOT SCALE DRAWING

REVISION

**02**



Reid Lifting Limited. Unit 1  
Wyeview, Newhouse Farm Ind. Est.,  
Chepstow, Monmouthshire.  
NP16 6UD, UK

Tel +44(0)1291 620796  
Fax: +44(0)1291 626490

[www.reidlifting.com](http://www.reidlifting.com)

[enquiries@reidlifting.com](mailto:enquiries@reidlifting.com)

	NAME	DATE
DRAWN	SS	05/07/2021
CHK'D		
APP'VD	CM	15/11/2022

UNLESS OTHERWISE SPECIFIED:  
DIMENSIONS ARE IN MILLIMETERS

ALL COPYRIGHT AND DESIGN RIGHT SUBSISTING IN THIS DOCUMENT IS THE PROPERTY OF REID LIFTING LIMITED AND MAY NOT BE REPRODUCED WITHOUT REID LIFTING'S CONSENT. THIS DOCUMENT AND THE INFORMATION CONTAINED WITHIN IT IS CONFIDENTIAL AND MAY NOT BE DISCLOSED TO ANY THIRD PARTY NOR USED FOR ANY UNAUTHORISED PURPOSE WITHOUT REID LIFTING'S CONSENT



TITLE: **Porta-Gantry Rapide Tall  
Frame WLL1000kg 3000mm  
Beam - Adjustable Feet**

DWG NO.

**PGR1TT30K**

A4

Estimated Weight: 64kg

1:30

SHEET 2 OF 2

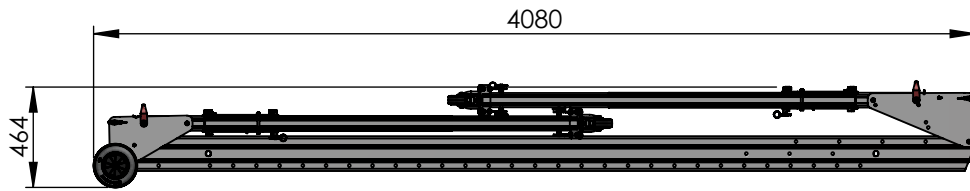

Folded

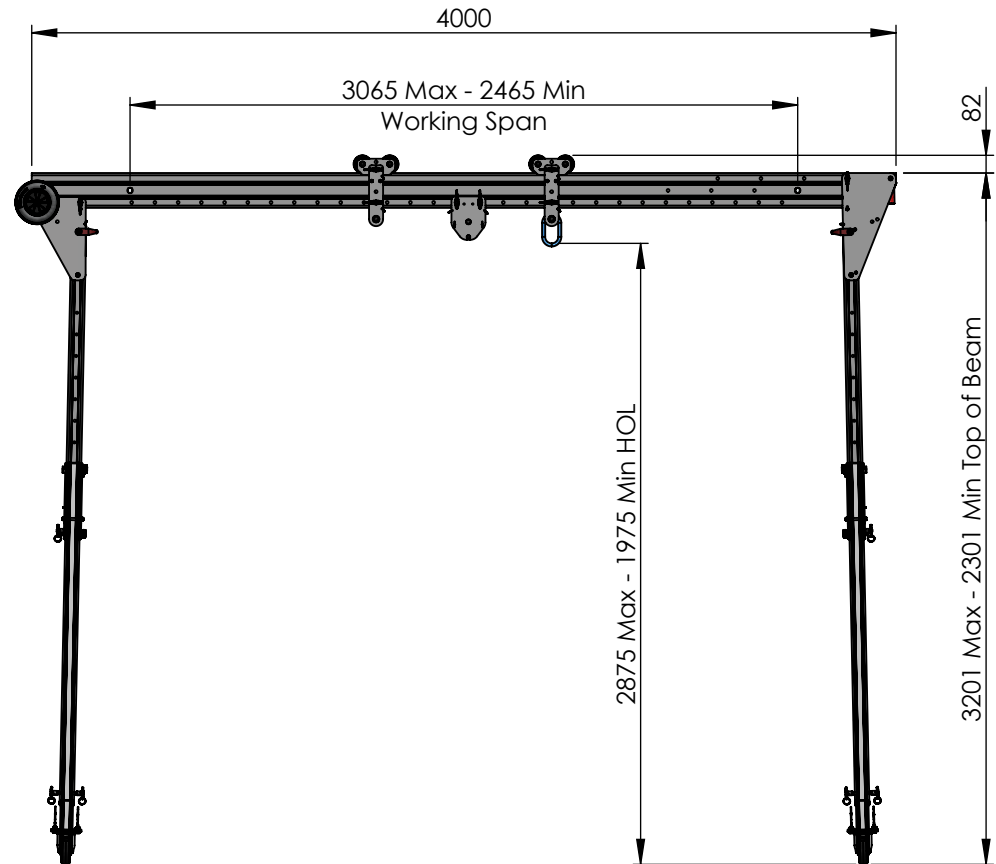
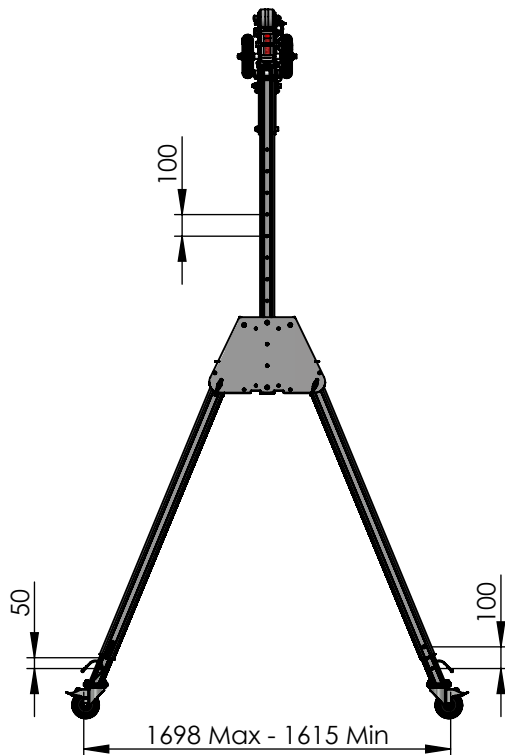
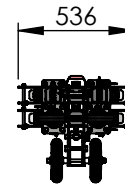

DO NOT SCALE DRAWING

REVISION **02**



Reid Lifting Limited. Unit 1  
Wyeview, Newhouse Farm Ind. Est.,  
Chepstow, Monmouthshire.  
NP16 6UD, UK  
Tel +44(0) 1291 620796  
Fax +44(0) 1291 626490

[www.reidlifting.com](http://www.reidlifting.com)

[enquiries@reidlifting.com](mailto:enquiries@reidlifting.com)

	NAME	DATE	FINISH:
DRAWN	SS	01/07/2021	Anodised
CHK'D			MATERIAL:
APPV'D	CM	15/11/2022	Aluminium Alloy
<small>ALL COPYRIGHT AND DESIGN RIGHT SUBSISTING IN THIS DOCUMENT IS THE PROPERTY OF REID LIFTING LIMITED AND MAY NOT BE REPRODUCED WITHOUT REID LIFTING'S CONSENT. THIS DOCUMENT AND THE INFORMATION CONTAINED WITHIN IT IS CONFIDENTIAL AND MAY NOT BE DISCLOSED TO ANY THIRD PARTY NOR USED FOR ANY UNAUTHORISED PURPOSE WITHOUT REID LIFTING'S CONSENT</small>			
UNLESS OTHERWISE SPECIFIED:			
DIMENSIONS ARE IN MILLIMETERS			



TITLE:	<b>Porta-Gantry Rapide Tall Frame WLL1000kg 4000mm Beam - Castors</b>	
DWG NO.	<b>PGR1TT40J</b>	A4
Estimated Weight:	69kg	1:35
		SHEET 1 OF 2

## General Specification

- Maximum rated capacity for goods lifting - 1000kg
- Maximum rated capacity for personnel lifting - 500kg
- Beam deflection at maximum rated capacity of 1000kg - 30-45 mm at centre of span
- Maximum castor surface pressure at full load - 16.96 MPa
- Assembled gantry weight (excluding trolleys) - 69kg
- All welding to BS EN ISO 15614-2: 2005 by certified welders.
- For further details and assembly information refer to Operations and Maintenance Manual for Porta Gantry Rapide Product. (available at [www.reidlifting.com](http://www.reidlifting.com))

## Fall Protection Standards

- Certified to EN795:2012 Type B & supplied under PPE Regulation 2016/425
- Notified Body Witness tested to the requirements of PD CEN/TS16415:2013 for 3 persons
- Exceeds the requirements of IRATA ICOP & BS7985 (15kN MBL)

## Materials & Finishes

- Frame and beam - 6082 T6 Aluminium alloy. Anodised.
- Castors - Steel. Bright Zinc Plated.
- Castor Wheels & Rollers - Nylon & Rubber
- Fixings - Steel. Grade 12:9. Bright Zinc Plated.

Note: Trolleys & Sheave Carrier shown in system as a reference



DO NOT SCALE DRAWING

REVISION

**02**



Reid Lifting Limited. Unit 1  
Wyeview, Newhouse Farm Ind. Est.,  
Chepstow, Monmouthshire.  
NP16 6UD, UK

Tel +44(0)1291 620796  
Fax: +44(0)1291 626490

[www.reidlifting.com](http://www.reidlifting.com)

[enquiries@reidlifting.com](mailto:enquiries@reidlifting.com)

	NAME	DATE
DRAWN	SS	01/07/2021
CHK'D		
APP'VD	CM	15/11/2022

UNLESS OTHERWISE SPECIFIED:  
DIMENSIONS ARE IN MILLIMETERS

ALL COPYRIGHT AND DESIGN RIGHT SUBSISTING IN THIS DOCUMENT IS THE PROPERTY OF REID LIFTING LIMITED AND MAY NOT BE REPRODUCED WITHOUT REID LIFTING'S CONSENT. THIS DOCUMENT AND THE INFORMATION CONTAINED WITHIN IT IS CONFIDENTIAL AND MAY NOT BE DISCLOSED TO ANY THIRD PARTY NOR USED FOR ANY UNAUTHORISED PURPOSE WITHOUT REID LIFTING'S CONSENT



TITLE: **Porta-Gantry Rapide Tall  
Frame WLL1000kg 4000mm  
Beam - Castors**

DWG NO.

**PGR1TT40J**

A4

Estimated Weight: 69kg

1:30

SHEET 2 OF 2

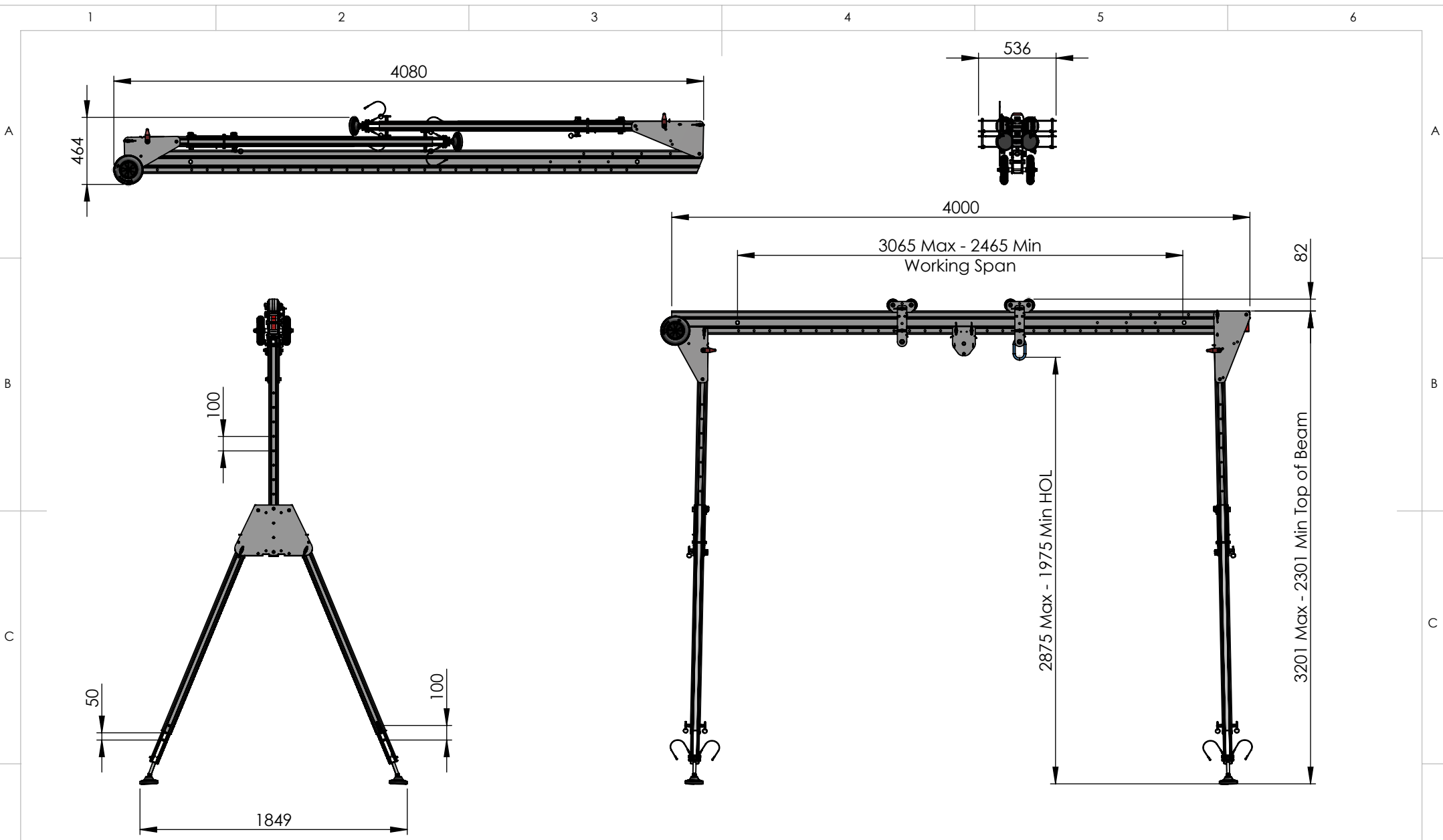

DO NOT SCALE DRAWING

REVISION **03**



Reid Lifting Limited. Unit 1  
 Wyeview, Newhouse Farm Ind. Est.,  
 Chepstow, Monmouthshire.  
 NP16 6UD, UK  
 Tel +44(0) 1291 620796  
 Fax +44(0) 1291 626490

[www.reidlifting.com](http://www.reidlifting.com)

[enquiries@reidlifting.com](mailto:enquiries@reidlifting.com)

	NAME	DATE	FINISH:
DRAWN	BJ	10/03/2021	Anodised
CHK'D			MATERIAL:
APPV'D	CM	15/11/2022	Aluminium Alloy
<small>ALL COPYRIGHT AND DESIGN RIGHT SUBSISTING IN THIS DOCUMENT IS THE PROPERTY OF REID LIFTING LIMITED AND MAY NOT BE REPRODUCED WITHOUT REID LIFTING'S CONSENT. THIS DOCUMENT AND THE INFORMATION CONTAINED WITHIN IT IS CONFIDENTIAL AND MAY NOT BE DISCLOSED TO ANY THIRD PARTY NOR USED FOR ANY UNAUTHORISED PURPOSE WITHOUT REID LIFTING'S CONSENT</small>			
<small>UNLESS OTHERWISE SPECIFIED:          DIMENSIONS ARE IN MILLIMETERS</small>			

TITLE:  
**Porta-Gantry Rapide Tall Frame**  
**WLL1000kg 4000mm Beam -**  
**Adjustable Feet**

DWG NO.	<b>PGR1TT40K</b>	A4
Estimated Weight:	69 kg	1:35
		SHEET 1 OF 2

## General Specification

- Maximum rated capacity for goods lifting - 1000kg
- Maximum rated capacity for personnel lifting - 500kg
- Beam deflection at maximum rated capacity of 1000kg - 35-40 mm at centre of span
- Maximum pad surface pressure at full load - 0.53 MPa
- Assembled gantry weight (excluding trollies) - 69kg
- All welding to BS EN ISO 15614-2: 2005 by certified welders.
- For further details and assembly information refer to Operations and Maintenance Manual for Porta Gantry Product. (available at [www.reidlifting.com](http://www.reidlifting.com))

## Fall Protection Standards

- Certified to EN795:2012 Type B & supplied under PPE Regulation 2016/425
- Notified Body Witness tested to the requirements of PD CEN/TS16415:2013 for 3 persons
- Exceeds the requirements of IRATA ICOP & BS7985 (15kN MBL)
- Tested to and meets the requirements of ANSI Z359.18.2017 for 2 persons.

## Materials & Finishes

- Frame and beam - 6082 T6 Aluminium alloy. Anodised.
- Castors - Steel. Bright Zinc Plated.
- Castor Wheels & Rollers - Nylon & Polyurethane
- Fixings - Steel. Grade 12.9. Bright Zinc Plated.

Note: Trolleys & Sheave Carrier shown in system as a reference



Approved

DO NOT SCALE DRAWING

REVISION

**03**

	NAME	DATE
DRAWN	BJ	10/03/2021
CHK'D		
APPV'D	CM	15/11/2022

UNLESS OTHERWISE SPECIFIED:  
DIMENSIONS ARE IN MILLIMETERS

ALL COPYRIGHT AND DESIGN RIGHT SUBSISTING IN THIS DOCUMENT IS THE PROPERTY OF REID LIFTING LIMITED AND MAY NOT BE REPRODUCED WITHOUT REID LIFTING'S CONSENT. THIS DOCUMENT AND THE INFORMATION CONTAINED WITHIN IT IS CONFIDENTIAL AND MAY NOT BE DISCLOSED TO ANY THIRD PARTY NOR USED FOR ANY UNAUTHORISED PURPOSE WITHOUT REID LIFTING'S CONSENT



TITLE: **Porta-Gantry Rapide Tall Frame WLL1000kg 4000mm Beam - Adjustable Feet**

DWG NO.

**PGR1TT40K**

A4

Estimated Weight: 69 kg

1:30

SHEET 2 OF 2



Reid Lifting Limited. Unit 1  
Wyeview, Newhouse Farm Ind. Est.,  
Chepstow, Monmouthshire.  
NP16 6UD, UK

Tel +44(0)1291 620796  
Fax: +44(0)1291 626490

[www.reidlifting.com](http://www.reidlifting.com)

[enquiries@reidlifting.com](mailto:enquiries@reidlifting.com)