

VMMS16
16 TONNE CAPACITY MACHINERY MOVING SKATE

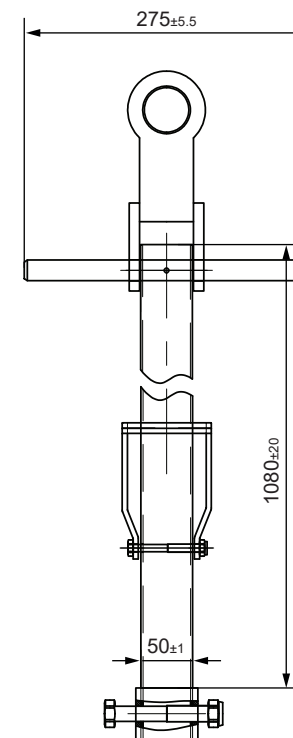

1. VMMS8S

HAND LEVER

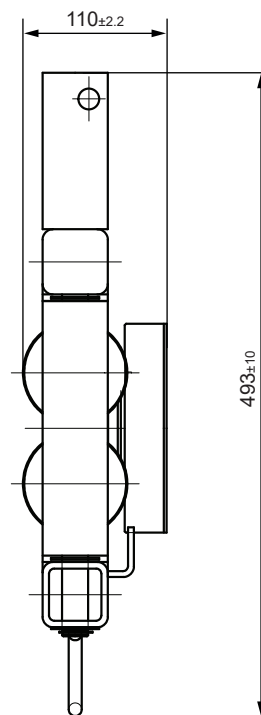
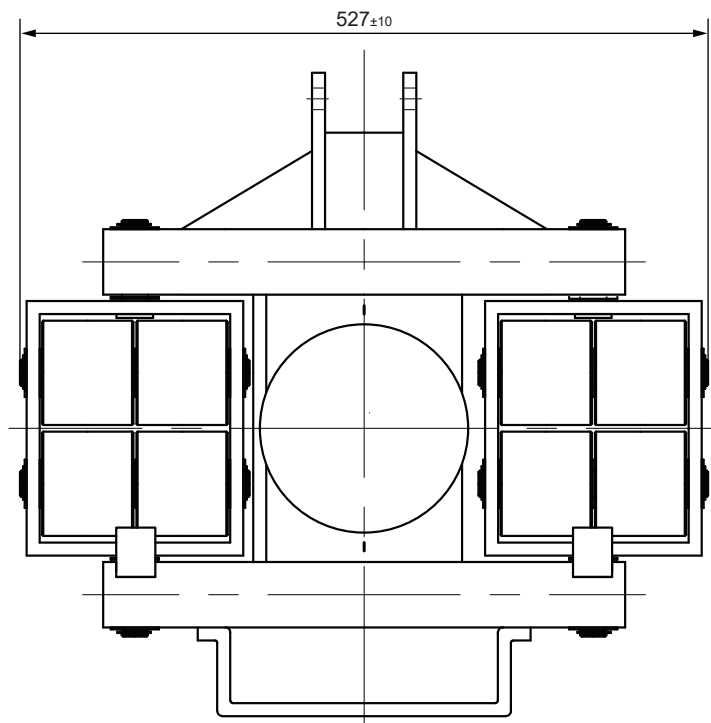
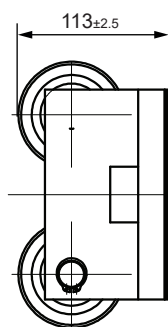
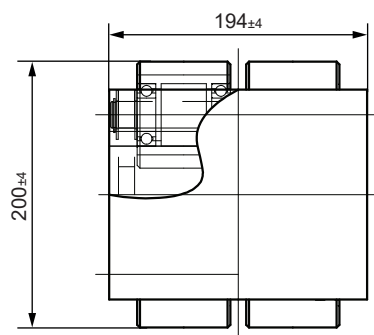

2. VMMS4T

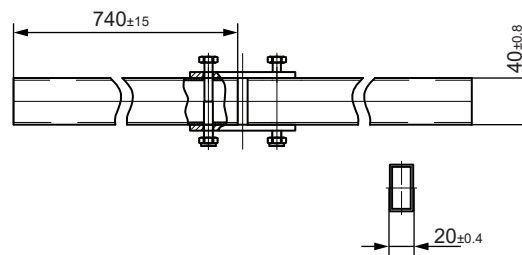

CONNECTOR BAR

Assembly (16t) consists of the following:		
Item	Product	Qty
1.	VMMS8S - 8T STEERING SECTION	1
2.	VMMS4T - 4T TRAILING SECTION	2
3.	TRAILING SECTION CONNECTOR BAR	1
4.	STEERING SECTION HAND LEVER	1

16 TONNE MACHINERY
MOVING SKATE SET

APPROVED	DATE
Josh Ranford	17.11.2022
Drawing ID	VMMS16/171122GT

PAGE 1 OF 1



GEORGE TAYLOR
LIFTING GEAR
(MIDLANDS) LTD.