

User Instructions & Safety Manual



Machinery Moving Skate

**Set Capacities
2 through to 64 tonnes**

Note: Operator must read and fully understand the operating instructions before using this product.

Products supplied comply with the essential health & safety requirements of the Machinery Directive 2006/42/EC, the Supply of Machinery (Safety) Regulations 2008 and the Health & Safety at Work etc Act 1974 section 6.

George Taylor & Company maintain a policy of progressive development of products and reserve the right to alter, without notice, the specifications shown within this manual.



www.gtlifting.co.uk

George Taylor & Company Lifting Gear (Midlands) Ltd.
Unit 4, Fryers Road, Walsall WS2 7LZ UK

T +44 (0)1922 490220 **F** +44 (0)1922 490229 **E** office@gtlifting.co.uk

Safety Information



All of the information reported herein is based on data available at the time of publishing. We reserve the right to modify the products at any time without notice. Please verify with us for possible updates.

GENERAL

Viper machinery skates have load bearing centres and are capable of moving large capacities. In saving time and straining, they are the ideal tool for carrying and shifting equipment, from small to heavy loads. Detailed below are various options available:



CRA-TYPE

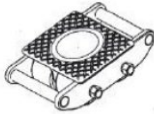

CRO-TYPE

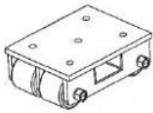

CRM-TYPE

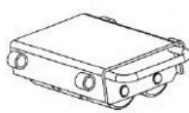

CRE-TYPE

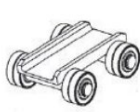

CTG-TYPE

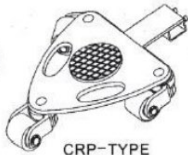

CRP-TYPE

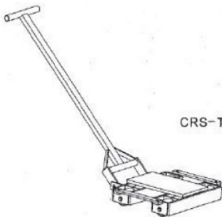

CRS-TYPE

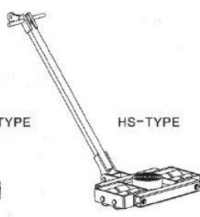

HS-TYPE



For your safety and correct operation, please carefully read the manual before use.

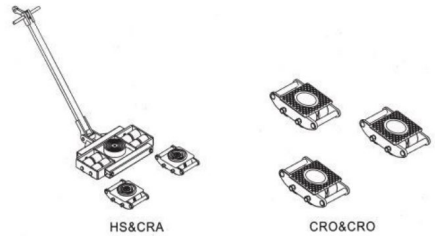

1. After lifting the cargo, please the skates in the appropriate place to support the load.
2. Gently lower the cargo onto the skate. Pull the draw bar or push the skate to move the load.
3. After the load has been repositioned, lift the cargo off the skates and move them out of the way before lowering the load back into place.

Safety Information



REMARKS

1. Ensure the load is always in uniform position on the bearing centre plate of the skates.
2. Always keep the surface on which the skate is placed, clean and smooth. **DO NOT USE ON UNEVEN SURFACES.**
3. Never exceed the maximum load of any skate.
4. Always use the correct equipment to load the skate, such as toe jacks etc.
5. When loading the skate set, make sure the load is distributed in such a way that each individual skate is not overlooked.
6. Make sure the load will not tip over from the skate.
7. Make sure the load is not unstable on the skate and avoid any risk of the load tipping over or falling from the skate.
8. When moving loads on a floor that has a slope make sure you have means of controlling the movement of the load once it starts moving.
9. Always ensure the floor is clean and free from any items that could damage the wheels of the skates.

PERSONAL PROTECTION

1. Always wear safety boots when moving heavy loads.
2. Do not put feet or hands under the load once it is placed on the skates.
3. When handling the skates, only lift the skates by the handles on the 16 and 36 tonne sets to avoid any risk of trapped fingers.
4. When moving the load on the skate, always ensure that there is no risk of any person becoming trapped by the moving load.

SET SPECIFICATIONS

- **8 tonne (X4+Y4) =**
1 x 4 tonne steering skate with turntable (X4)
2 x 2 tonne trailing skates (Y4)
- **16 tonne (X8+Y8) =**
1 x 8 tonne steering skate with turntable (X8)
2 x 4 tonne trailing skates (Y8)
- **24 tonne (X12+Y12) =**
1 x 12 tonne steering skate with turntable (X12)
2 x 6 tonne trailing skates (Y12)
- **32 tonne (X16+Y16) =**
1 x 16 tonne steering skate with turntable (X16)
2 x 8 tonne trailing skates (Y16)
- **36 tonne (X18+Y18) =**
1 x 18 tonne steering skate with turntable (X18)
2 x 9 tonne trailing skates (Y18)
- **48 tonne (X24+Y24) =**
1 x 24 tonne steering skate with turntable (X24)
2 x 12 tonne trailing skates (Y24)
- **64 tonne (X32+Y32) =**
1 x 32 tonne steering skate with turntable (X32)
2 x 16 tonne trailing skates (Y32)

MAINTENANCE

Inspect the skates on a regular basis and before use, to ensure they are in a safe to use condition.

Keep the wheels clean and remove any metal items that have become embedded in the wheels.

Lubricate the wheels to allow the skates to continue to move freely, making moving the load easier.

Spare Parts Breakdown



VRS2 - 2 tonne

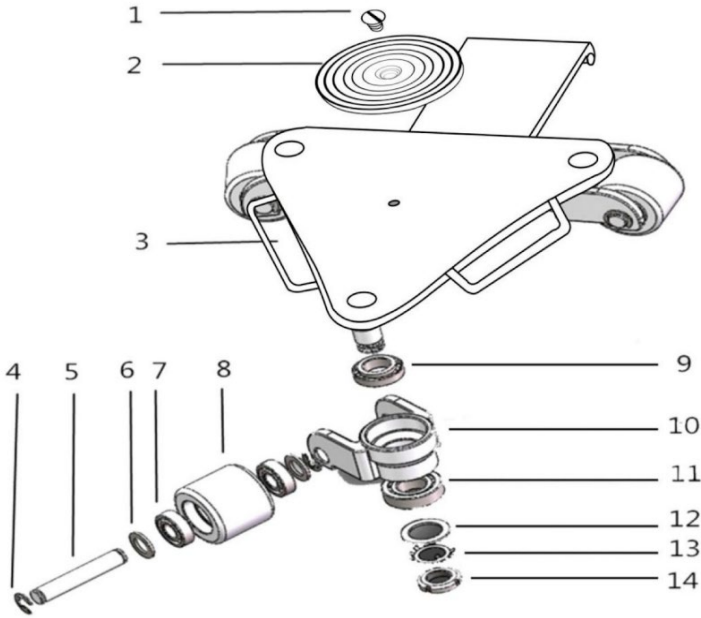

Fig. No.	Description	Qty
1.	Turntable Screw	1
2.	Turntable	1
3.	Frame	1
4.	Open Ring	6
5.	Roller Shaft	3
6.	Flat Washers	6
7.	Bearing 1	6

Fig. No.	Description	Qty
8.	Roller	3
9.	Bearing 2	3
10.	Wheel Frame	3
11.	Bearing 3	3
12.	Washer	3
13.	Locking Washers	3
14.	Locking Nuts	3

Spare Parts Breakdown



VRS4 - 4 tonne

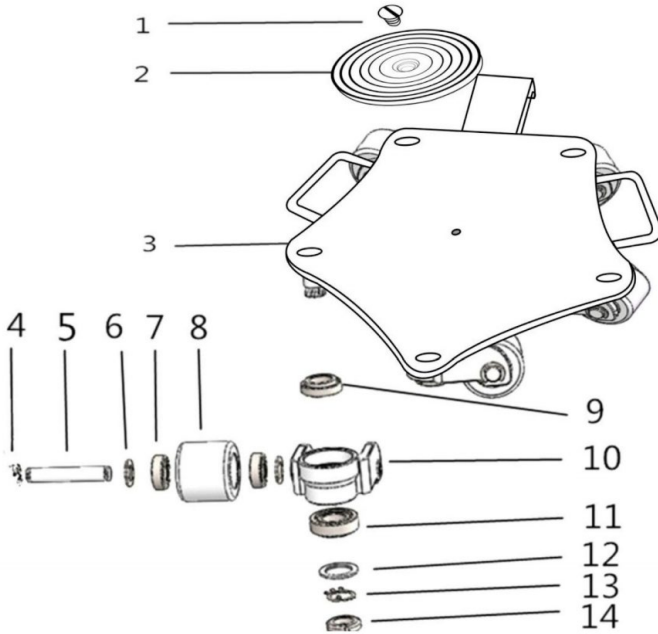

Fig. No.	Description	Qty
1.	Turntable Screw	1
2.	Turntable	1
3.	Frame	1
4.	Open Ring	10
5.	Roller Shaft	5
6.	Flat Washers	10
7.	Bearing 1	10

Fig. No.	Description	Qty
8.	Roller	5
9.	Bearing 2	5
10.	Wheel Frame	5
11.	Bearing 3	5
12.	Washer	5
13.	Locking Washers	5
14.	Locking Nuts	5

Spare Parts Breakdown



X4 - VMMS8 - Steering Skate

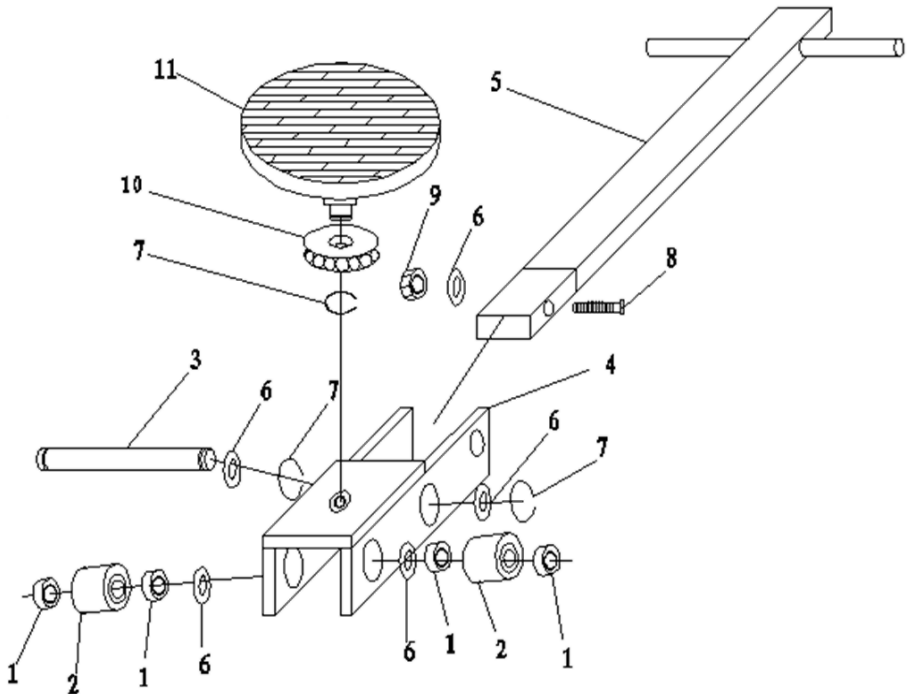

Fig. No.	Description	Qty
1.	Bearing	8
2.	Wheel	4
3.	Axle	2
4.	Frame	1
5.	Handle	1
6.	Washer	9

Fig. No.	Description	Qty
7.	Retaining Ring	5
8.	Bolt	1
9.	Nut	1
10.	Bearing	1
11.	Crest Plank Arts	1

Spare Parts Breakdown



Y4 - VMMS8 - Trailing Skate

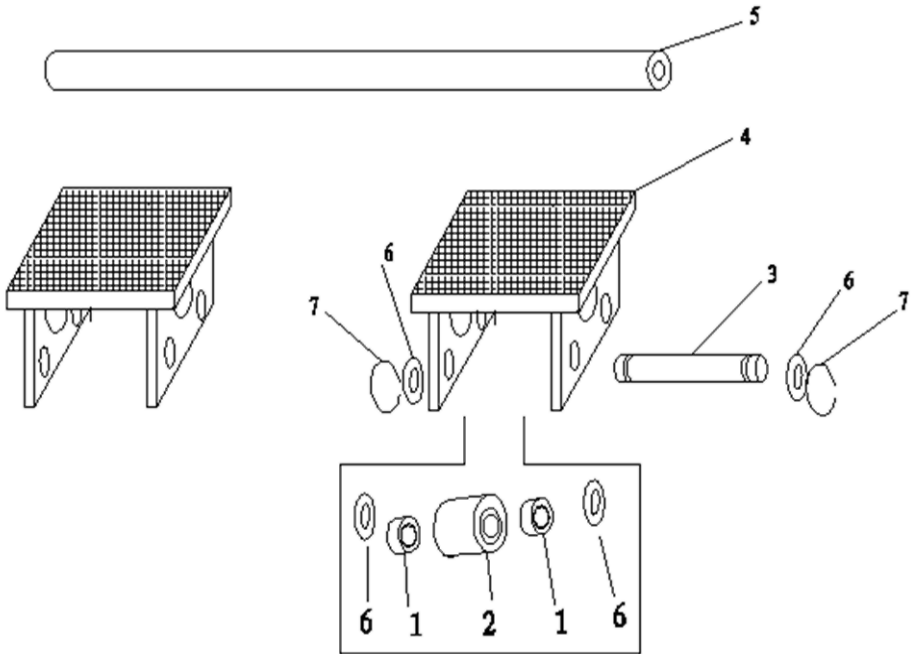

Fig. No.	Description	Qty
1.	Bearing	8
2.	Wheel	4
3.	Axle	2
4.	Frame	1

Fig. No.	Description	Qty
5.	Connect Rod	1
6.	Washer	9
7.	Retaining Ring	5

Spare Parts Breakdown



X8 - VMMS16 - Steering Skate

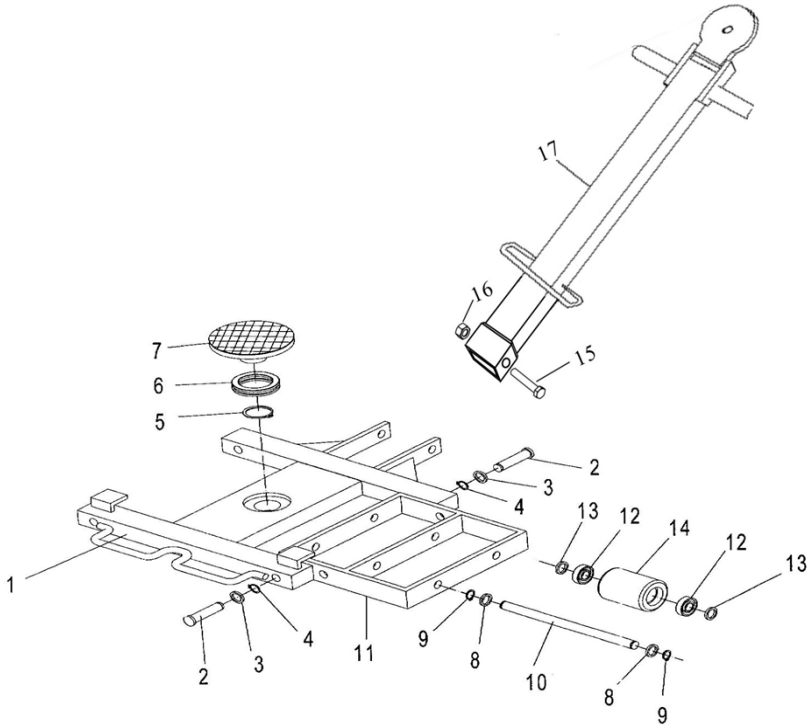

Fig. No.	Description	Qty
1.	Frame	1
2.	Shaft	4
3.	Washer	4
4.	Retaining Ring	4
5.	Retaining Ring	1
6.	Bearing	1
7.	Crest Plank Arts	1
8.	Washer	8
9.	Retaining Ring	8

Fig. No.	Description	Qty
10.	Axle	4
11.	Frame of Roller	2
12.	Bearing	16
13.	Washer	16
14.	Wheel	8
15.	Bolt	1
16.	Nut	1
17.	Handle	1



Y8 - VMMS16 - Trailing Skate

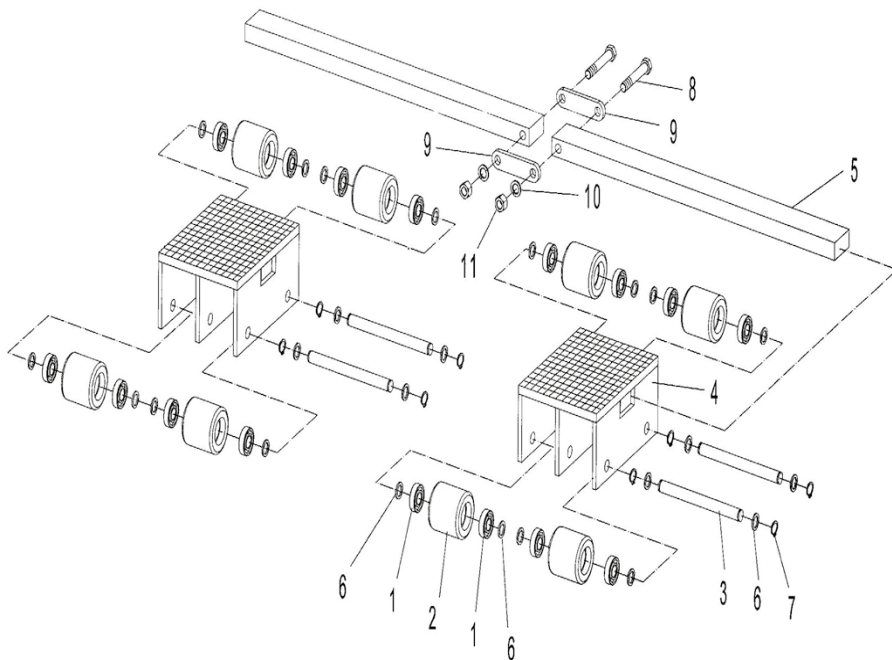

Fig. No.	Description	Qty
1.	Bearing	16
2.	Wheel	8
3.	Axle	4
4.	Frame	2
5.	Connect Rod	2
6.	Washer	26

Fig. No.	Description	Qty
7.	Retaining Ring	8
8.	Bolt	2
9.	Connect Plank	2
10.	Elastic Washer	2
11.	Nut	2

Spare Parts Breakdown



X12 - VMMS24 - Steering Skate

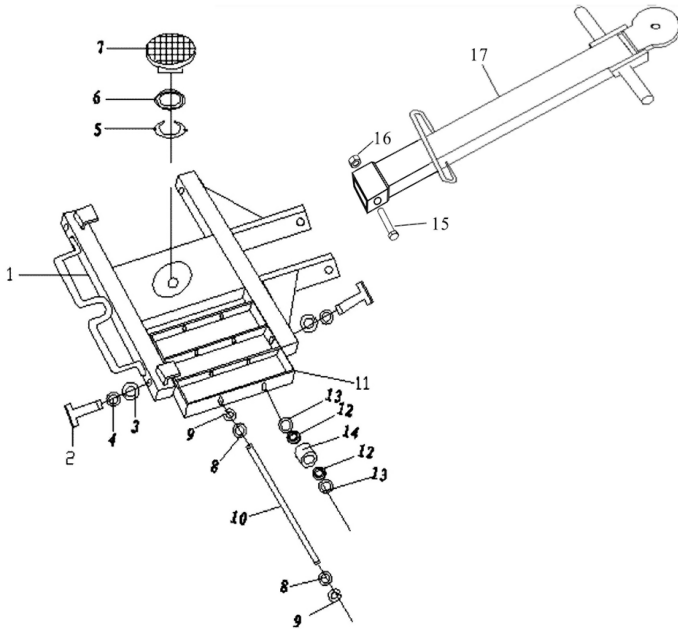

Fig. No.	Description	Qty
1.	Frame	1
2.	Shaft	4
3.	Washer	4
4.	Retaining Ring	4
5.	Retaining Ring	1
6.	Bearing	1
7.	Crest Plank Arts	1
8.	Washer	8
9.	Retaining Ring	8

Fig. No.	Description	Qty
10.	Axle	4
11.	Frame of Roller	2
12.	Bearing	24
13.	Washer	24
14.	Wheel	12
15.	Bolt	1
16.	Nut	1
17.	Handle	1

Y12 - VMMS24 - Trailing Skate

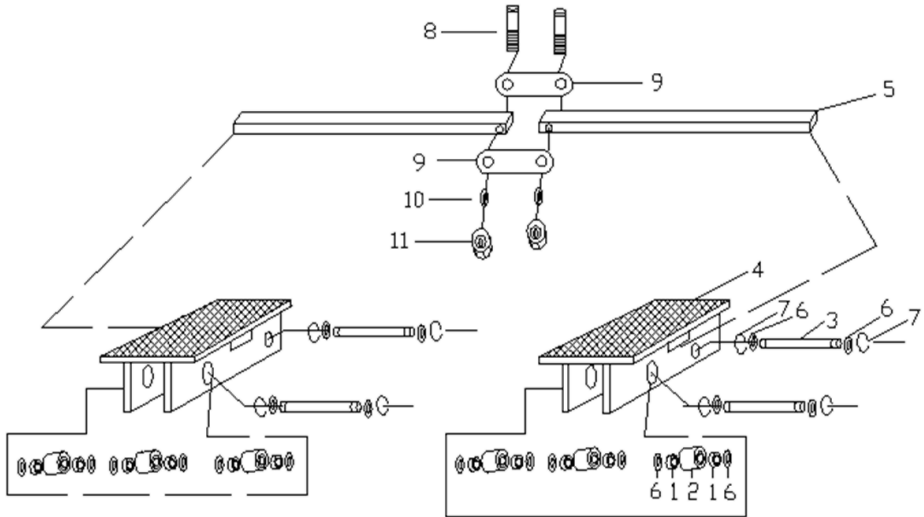

Fig. No.	Description	Qty
1.	Bearing	24
2.	Wheel	12
3.	Axle	4
4.	Frame	2
5.	Connect Rod	2
6.	Washer	24

Fig. No.	Description	Qty
7.	Retaining Ring	4
8.	Bolt	2
9.	Connect Plank	2
10.	Elastic Washer	2
11.	Nut	2

Spare Parts Breakdown



X18 - VMMS36 - Steering Skate

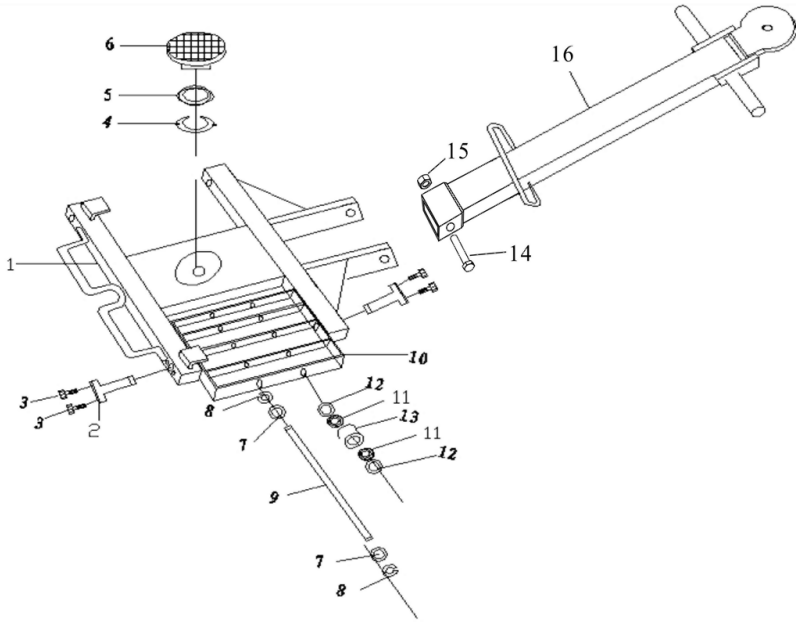

Fig. No.	Description	Qty
1.	Frame	1
2.	Shaft	4
3.	Bolt	4
4.	Retaining Ring	1
5.	Bearing	1
6.	Crest Plank Arts	1
7.	Washer	8
8.	Retaining Ring	8

Fig. No.	Description	Qty
9.	Axle	4
10.	Frame of Roller	2
11.	Bearing	36
12.	Washer	36
13.	Wheel	18
14.	Bolt	1
15.	Nut	1
16.	Handle	1

Y18 - VMMS36 - Trailing Skate

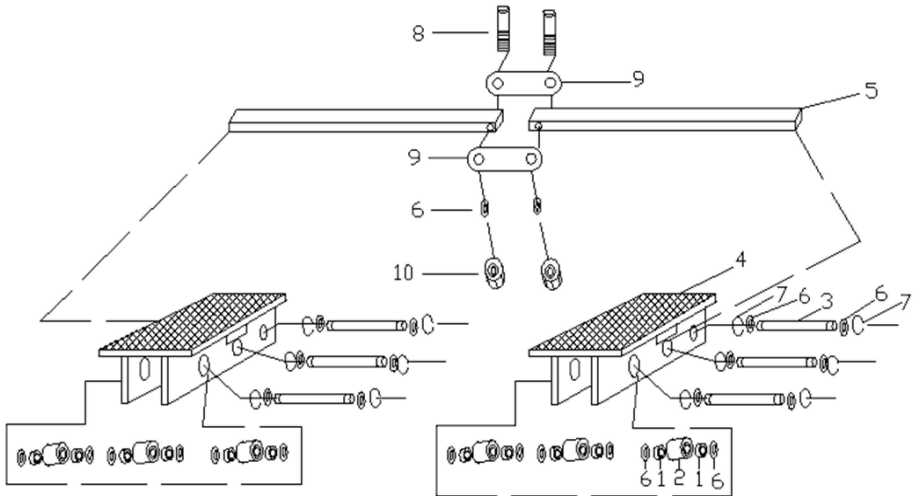

Fig. No.	Description	Qty
1.	Bearing	36
2.	Wheel	18
3.	Axle	4
4.	Frame	2
5.	Connect Rod	2
6.	Washer	36

Fig. No.	Description	Qty
7.	Retaining Ring	4
8.	Bolt	2
9.	Connect Plank	2
10.	Elastic Washer	2
11.	Nut	2

Spare Parts Breakdown



X24 - VMMS48 - Steering Skate

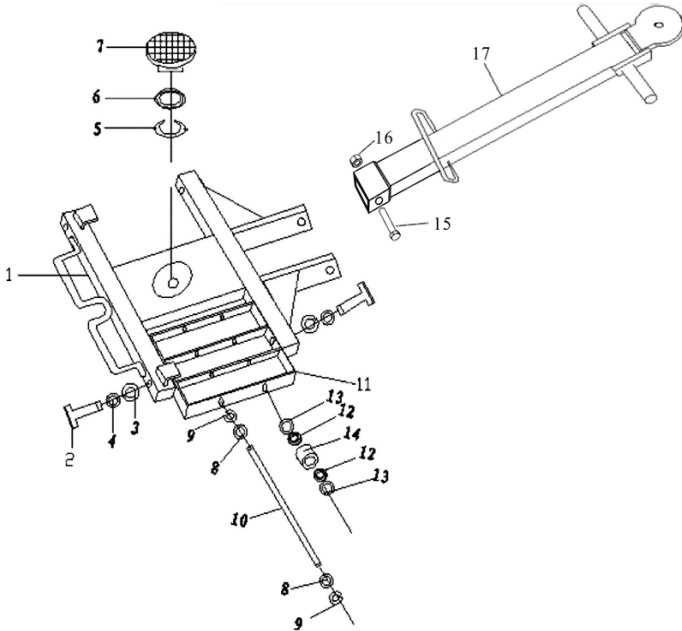

Fig. No.	Description	Qty
1.	Frame	1
2.	Shaft	4
3.	Washer	4
4.	Retaining Ring	4
5.	Retaining Ring	1
6.	Bearing	1
7.	Crest Plank Arts	1
8.	Washer	8
9.	Retaining Ring	8

Fig. No.	Description	Qty
10.	Axle	4
11.	Frame of Roller	2
12.	Bearing	24
13.	Washer	24
14.	Wheel	12
15.	Bolt	1
16.	Nut	1
17.	Handle	1



Y24 - VMMS48 - Trailing Skate

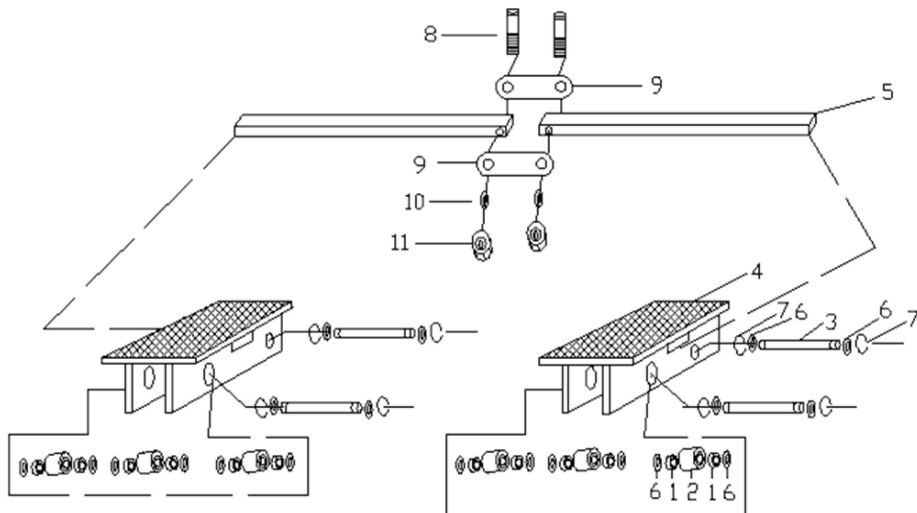

Fig. No.	Description	Qty
1.	Bearing	24
2.	Wheel	12
3.	Axle	4
4.	Frame	2
5.	Connect Rod	2
6.	Washer	24

Fig. No.	Description	Qty
7.	Retaining Ring	4
8.	Bolt	2
9.	Connect Plank	2
10.	Elastic Washer	2
11.	Nut	2



www.gtlifting.co.uk

George Taylor & Company Lifting Gear (Midlands) Ltd.
Unit 4, Fryers Road, Walsall WS2 7LZ UK

T +44 (0)1922 490220 **F** +44 (0)1922 490229 **E** office@gtlifting.co.uk